



NITTA MOORE

Hoses, Hose couplings & Adaptors

**Linemate**<sup>®</sup>

CATA-10010A-04E

<http://www.nittamoore.co.jp>

CAD diagrams can be downloaded from our web site



Nitta Moore Company has received ISO14001 and ISO9001 certifications.

# Features of Nitta Moore thermoplastic hoses

## Clean and Eco-friendly

Smooth inner surface of the plastic hoses keeps the operating oil clean.

## Piping on Site

With the one-touch coupling “CAMPUCKA” or assembly tool “Mark 10,” it is easy to adjust length on site.

## High Durability

They are highly durable against impact pressure and repeated bending, because of the synthetic fiber reinforcement.

## High Abrasion Resistance

They have high abrasion resistance because special polyurethane resin is used as the cover material.

## Light

They weigh only about a quarter to half that of rubber hoses.

## Compact Piping

Small outer diameter enables piping in small bending radius.

CAD diagrams of hose couplings and adaptors can be downloaded from our web site.

<http://www.nittamoore.co.jp>

# INDEX

<b>Features of Nitta Moore thermoplastic hoses</b>	<b>1</b>
<b>Precautions for use</b>	<b>3</b>
<b>Hose products</b>	<b>5</b>
How to order	6
Hose selection table	7
Types of hose couplings for several hose-assembling methods	9
List of adaptor connection shapes	10
LF70 Series <b>Linemate</b> <sup>®</sup>	13
000/1100/1400/1500 Series <b>Linemate</b> <sup>®</sup>	17
1000 (light gray) Series <b>Linemate</b> <sup>®</sup>	23
F3130 (light gray) Series <b>Linemate</b> <sup>®</sup>	25
N3130/3130/3000 Series <b>Linemate</b> <sup>®</sup>	27
3700 Series <b>Linemate</b> <sup>®</sup>	28
N3000 Series <b>Linemate</b> <sup>®</sup>	37
HT Series <b>Linemate</b> <sup>®</sup>	37
3R80 Series <b>Linemate</b> <sup>®</sup>	41
3V10/3VE0Series	45
5501 Series <b>Linemate</b> <sup>®</sup>	47
3450 Series <b>Linemate</b> <sup>®</sup>	47
34PW Series	49
35NG Series	51
<b>Adaptor Products</b>	<b>53</b>
Adaptor / List of hose connection shapes	
<b>Hose Guard Parts and Specially-Treated Parts</b>	<b>65</b>
Hose specially-treated parts / Hose guard parts	
<b>Hose Assembly Machine Tool, Special Jigs and Tools</b>	<b>69</b>
Hose assembly tools / Hose assembly special jigs / Hose assembly tools	
<b>Hose Assembling Methods</b>	<b>73</b>
Campucka coupling / Swage coupling (With Mark 10) / Swage coupling (With Mark 9) / Reusable coupling	
<b>Technical Document</b>	<b>83</b>
How to select a hose / How to select the hose length / How to select the hose size for given flow volume and velocity / Volumetric expansion of hoses / Tightening torque of hose couplings and adaptors	
<b>Reference Document</b>	<b>91</b>
Standard for threads / Standard for thermoplastic hoses /Unit conversion table / Example of problems at improper hose assembly / Chemical resistance table	

Hydraulic  
Hose

Airless-  
painting  
Hose

Clean  
Hose

Natural-Gas  
Hose

Adaptor

Hose Guard  
Part, Specially-  
Treated Part

Assembling  
Machine,  
Jig, Tool

Hose  
Assembling  
Method

Technical  
Document

Reference  
Document

## ⚠️ Precautions for Use

These “Precautions for Use” provide instructions for the correct use of our product to prevent damage to people and property. The instructions are classified into three categories, “danger,” “warning,” and “caution,” depending on the extent of damage from improper use. Every category contains important notes for safety so please follow these as well as ISO 4414-1982 (\*1), JIS B 8370(1988)(\*2), ISO4413-1979(\*3), and JIS B 8361(1982)(\*4).

\*1 ISO4414-1982 Pneumatic fluid power …… Recommendations for the application of equipment to transmission and control systems.

\*2 JIS B 8370(1988) Pneumatic System General Rules

\*3 ISO4413-1979 Hydraulic fluid power …… General rules for the application of equipment to transmission and control systems.

\*4 JIS B 8361(1982) Hydraulic System General Rules

**⚠️ DANGER** For the limited cases of inappropriate use, where a dangerous situation leading to death or severe injury is expected and emergent warning is necessary at the occurrence of danger.

**⚠️ WARNING** For the cases of inappropriate use, where a dangerous situation leading to death or severe injury is expected.

**⚠️ CAUTION** For the cases of inappropriate use, where a dangerous situation leading to minor injury or light damage to property is expected.

For more safety information, please read the following carefully. Notes for each product are also given on the product page. Please read the instructions for use as well.

## Notes for the products in this catalog

Notes for the use of Assembling machines Mark 9 and 10 are also given in their instruction manual.

### ⚠️ Before Selection!

#### ⚠️ DANGER

- Cannot use for machines and equipment that maintain and control human life.
- Cannot use for machines and equipment that require an extremely high level of safety.

#### ⚠️ WARNING

- Designers of instruments, machines, or connecting systems or those who make specifications should consider the handling of our products. In such consideration, a test or analysis should be conducted if necessary. It is their responsibility to assure the given safety and performance of the instruments, the machines, or the systems.
- Those who have sufficient knowledge and experience should handle our products.
- Please do not handle and remove our products from instruments, machines, or systems until safety is confirmed.
- Please contact us when using our products in situations and conditions that are not assumed in the specifications described in the catalog.
- Please contact us when using our products for equipment, machines, various types of vehicles, and commercial aircraft, for leisure machines and equipment to transport humans, for medical equipment that would cause human damage if the specifications were inappropriately followed, and for machines in contact with food or drinking water.

### ⚠️ When Selecting!

#### ⚠️ WARNING

- Please check if the use condition satisfies the “use conditions” in the catalog.
- Do not use our products when a caustic or flammable gas is used as a fluid or is in the environment.
- Do not use our products in places where excessive vibration or impact may occur.
- Consult the “Table of chemical resistance” if chemicals are used as a fluid or in the environment.
- There are a limited group of hose couplings for each type of hose product. Please select correct combinations according to the specifications.
- Our hose products and hose couplings are not compatible with other company’s hose products and hose connectors.
- Each type of hose product allows the use of a limited type of fluid. Do not use a fluid that is not allowed.

- If use conditions are different between hose products and hose couplings, please use them following the smaller data.
- The hose product must be of an appropriate size to maintain the necessary flow volume. If the size is not appropriate, the increase in pressure drop and oil temperature could cause problems. The relation of fluid velocity, fluid volume, and hose inner diameter is given in “Nomograph.”
- The maximum impact pressure of hose products is approximately 1.5 times higher than the maximum working pressure. Since the impact pressure may affect hose life, please select appropriate hoses when the pressure exceeds the specified value.
- When electric insulation is necessary, for example in electrical works, please select “Nonconductive” hoses. Contact us for details.

#### ⚠️ CAUTION

- When water or glycol-type operating oil is used, hoses work without problem but some plated types of hose couplings cannot be used. Contact us for details.
- Hose products might change their length by  $\pm 3\%$  under pressure, so do not stretch hoses tightly.

### ⚠️ When Installing!

#### ⚠️ WARNING

- Instructions for connecting hoses are given in a separate document. Please read it and follow the instructions for installation.
- Do not use couplings with damaged threads and seat surface.
- If you use reusable products such as reusable couplings, ensure that they are not damaged.
- We will not guarantee the products which are additionally treated, decomposed or refabricated by others .
- For installation of hoses, please fix them in a place where unexpected disconnection of hose and couplings cannot cause damage to people or property.

#### ⚠️ CAUTION

- Prevent damaging the hoses, e.g. entanglement or abrasion. It could cause flattening, destruction, and disconnection.
- Install hoses to prevent loads such as tension, torsion, rotation, and bending with a radius under the minimum bending radius.

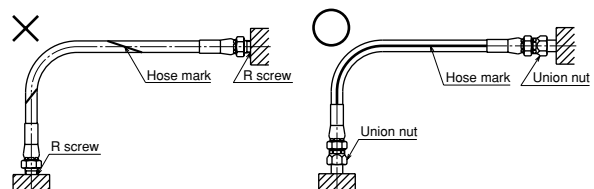



- Do not break a hose, which might cause “fatigue destruction” at the break point even under the maximum working pressure.

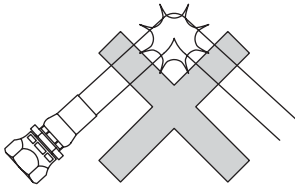

- When the plug-in part of the hose couplings is dirty, clean the surface.
- Do not use hoses if they have a dent or damage.
- Do not twist hose assemblies after pressure is applied. When they are twisted, it could deform the inner structure of the hoses and result in “destruction.”
- Do not throw and drop hose couplings, which might damage threads and sheets and lead to oil leakage.
- Tighten the hose coupling to the specified torque. Some material may expand or crack by the tightening, so check and confirm the strength of the part to be assembled. Sharply bending a hose near the coupling could shorten the life of the hose. When bending a hose, keep the hose straight of the length longer than the outer diameter of the hose from the assembled part.

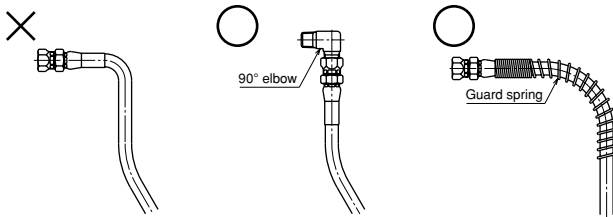

- Pressure on hose products could cause interference with surrounding parts on which no interference exists before the pressure is applied. Please handle appropriately, e.g. introducing guard parts.
- Do not over-tighten when using clamps such as INSULOK ties to fix a hose. Concentrated stress may cause “fatigue destruction.”

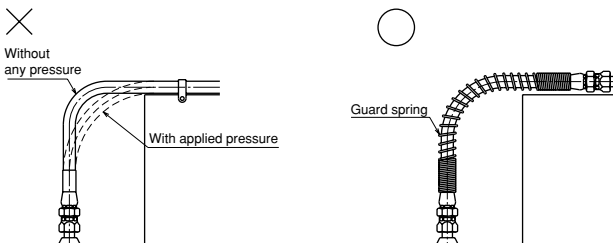

- Hose products are designed to withstand inner pressure, so do not apply outer pressure to them.
- You cannot reuse hoses and hose couplings except reusable couplings.
- Protect a hose from possible outer damage by using a wire braid or guard spring.
- Hoses keep the bending shape if they are left over a certain period of time. When removing and reinstalling a hose assembly for machine exchange, circuit inspection, repair, and so forth, please attach the hose in the original position. When attaching it, clean the threads and seat of the coupling and tighten it to the specified torque.

### ⚠ When Using!

#### ⚠ WARNING

- Do not touch hose products at the pressurization. If you improperly approach or touch a hose at the pressurization, it could be quite dangerous if an unexpected breakage of the hose or the coupling were to scatter fluid inside.
- Do not touch hose products when the fluid is hot. It could cause a “burn.”
- When “water” is used as a fluid, please keep it unfrozen.

### ⚠ When Storing!

#### ⚠ CAUTION

- If you store unused products, keep them in a clean place to prevent dust. When fine particles such as dust enter the inside, they also enter the connecting equipment and may cause problems.

### ⚠ When Maintaining!

#### ⚠ CAUTION

- Please conduct periodic inspection. Confirm that there is no degradation such as outer damage, corrosion, and abrasion as well as any distorted parts and replace it with a new one if necessary.
- Change the hose immediately if the outer damage or abrasion reaches, or is about to reach the synthetic fiber braid.

- Keep hose products in a dry place under 40°C avoiding direct sunlight.
- Store a hose in a straight position or in a coil with a larger diameter than the minimum bending diameter.
- Try to use hoses and couplings within about one year after the production.

# Hose products

<b><u>How to order hose assembly</u></b>	<b>6</b>
<b><u>Hose selection table</u></b>	<b>7</b>
<b><u>Types of hose couplings for hose-assembling methods</u></b>	<b>9</b>
<b><u>Hose couplings chart</u></b>	<b>10</b>

## Check the following usage conditions before ordering.

1. Type and volume of working fluid
2. Working pressure (maximum working pressure and maximum impact pressure: MPa)
3. Working temperature range (temperature of fluid and environment: °C)
4. Bending radius of hose (minimum bending radius: mm)

## Based on the above conditions, please follow the steps below.

1. Select the type of hose (A) and the inner diameter (D).
2. Indicate the length (L) of hose assembly. (Use the length between the edges of two couplings.)
3. Select types and materials of couplings (B and C) and adaptor (E).
4. Specify if guard spring and other accessories (F) are required. See P.67 for accessories.

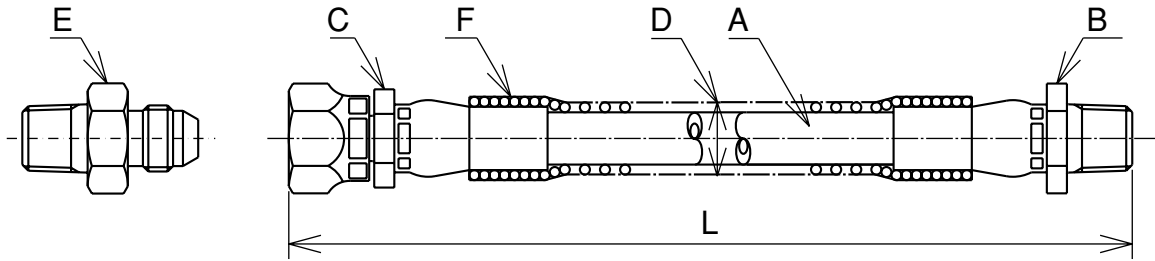

**N3130-04 1000L SA × SE + 010-G1**

**A** Type of hose

**D** Inner diameter of hose

**L** Length of hose assembly

**B** Type of one coupling

**F** Fitting shape of guard parts

(Ex) Below are the types of guard springs

G1: Full length

G2: Both ends (Please specify the length )

G3: Single end (Please specify the length and the direction of installation)

**E** Types of adaptor

**C** Types of the other couplings

# Hose selection table

- → Steel
  - ⊙ → Short steel (short-length type)
  - Ⓢ → Stainless
  - Ⓢ⊙ → Short stainless (short-length type)
- Made-to-order products are indicated by “△”.

☎ Contact us for other fluids.

				Hydraulic Piping										
Page				13 – 16		17 – 22				23 – 24	25 – 26	27 – 36		
Hose series				LF70	1000	1100	1400	1500	1000 (Light gray)	F3130 (Light gray)	*1 *3 N3130	3130	3000	
Size	I.D. (in.)	I.D.(mm)	Max. working pressure (MPa)											
02	1/8	3.6		—	—	—	—	—	—	20.0	—	20.0	—	
03	3/16	4.8		—	—	—	—	15.0	—	—	21.0*5	20.0*5	34.0*5	
04	1/4	6.3		7.0	10.5	10.5	14.0	—	10.5	19.5	19.5*5	20.0*5	30.0*5	
05	5/16	7.9		—	—	—	—	—	—	—	17.5	18.0	—	
06	3/8	9.5		7.0	10.5	10.5	14.0	—	10.5	16.0	16.0*5	18.0*5	24.0*5	
08	1/2	12.7		—	10.5	10.5	—	—	10.5	14.0	14.0*5	16.0*5	20.0*5	
10	5/8	15.9		—	—	—	—	—	—	—	—	—	—	
12	3/4	19.0		—	—	—	—	—	—	9.0	9.0*5	10.0*5	13.0*5	
16	1	25.4		—	—	—	—	—	—	7.0	7.0*5	—	10.0*5	
Temp. range (°C)				-40 – +100	-40 – +100 (for Campucka) -20 – +100	-40 – +100	-40 – +100 (for Campucka) -20 – +100	-40 – +100	-40 – +100	-40 – +100	-40 – +100	-40 – +100	-40 – +100	
Features				Super flexible, small bend radius	Thin, light	Outer wire braid	Thin, light	Thin, light	Thin, light, Campucka usable	Flexible, Campucka usable	Flexible	Reusable coupling usable	Reusable coupling usable	
Application				<ul style="list-style-type: none"> <li>● Machine tools</li> <li>● Construction machine</li> <li>● General operating machine, etc.</li> </ul>	<ul style="list-style-type: none"> <li>● Construction machine</li> <li>● Farming machine</li> <li>● Machine tools, etc.</li> </ul>	<ul style="list-style-type: none"> <li>● Machine tools, etc.</li> </ul>	<ul style="list-style-type: none"> <li>● Industrial vehicles</li> <li>● Farming machine, etc.</li> </ul>	<ul style="list-style-type: none"> <li>● Industrial vehicles</li> <li>● Farming machine, etc.</li> </ul>	<ul style="list-style-type: none"> <li>● Oil pressure of machine tools</li> <li>● Coolant piping</li> </ul>	<ul style="list-style-type: none"> <li>● Oil pressure of machine tools</li> <li>● Coolant piping</li> </ul>	<ul style="list-style-type: none"> <li>● Machine tools</li> <li>● Industrial vehicles</li> <li>● General operating machine</li> <li>● Robot</li> <li>● Utility piping in factory, etc.</li> </ul>	<ul style="list-style-type: none"> <li>● General industrial machine</li> <li>● Ship painting, etc.</li> </ul>	<ul style="list-style-type: none"> <li>● General industrial machine</li> <li>● Ship painting, etc.</li> </ul>	
Types of couplings (P.9)														
Shapes of couplings (P.10 – 11)														
Couplings that can be used	Swage	SA	⊙	⊙Ⓢ	⊙Ⓢ	⊙Ⓢ	○	○	○	○	○Ⓢ	○Ⓢ	○Ⓢ	
		SE	⊙	⊙Ⓢ	⊙Ⓢ	⊙Ⓢ	○	○	○	○	○Ⓢ	○Ⓢ	○Ⓢ	
		SF	⊙	⊙Ⓢ	⊙Ⓢ	⊙Ⓢ	○	○	○	○	○Ⓢ	○Ⓢ	○Ⓢ	
		SK		△	△	△		△		○	○	○	○	
		SO								○	○	○	○	
		SC		○	○	○		○		○	○	○	○	
		SLE								△	△	△	△	
		SL		○	○	○		○		○	○	○	○	
		AE (45° • 90°)		△	○	○	○		○		○	○	○	
		AF (45° • 90°)		⊙	○	○	○		○		○	○	○	
	AK (45° • 90°)			△	△	△		△		△	△	△		
	Reusable	A										○Ⓢ	○Ⓢ	
		E										○Ⓢ	○Ⓢ	
F											○Ⓢ*6	○Ⓢ*6		
Campucka	CA		○		○		○				○*4			
	CE		○		○		○		○*7		○*4			
	CF		○		○		○				○*4			

\*1 Matched to type A of JIS K 6375 (hydraulic braid-reinforced plastic hose), matched to SAE100R7.  
 \*2 Matched to type B of JIS K 6375 (hydraulic braid-reinforced plastic hose), matched to SAE100R8.  
 \*3 Nonconductive (electrically insulative). See P.85 for details.  
 \*4 Campucka coupling (made-to-order) is available for 3130-02.  
 \*5 Outer braid (of steel wire or stainless wire) is available.  
 \*6 Stainless F type is made-to-order.  
 \*7 When Campucka coupling is used, the max. working pressure is 10.5 MPa, while in case of F3130-02, 20.2MPa.



	Hydraulic Piping						For Airless-painting		For Clean Use	For Natural-gas	Page
	27 – 36	37 – 40		41 – 44	45 – 46		47 – 48		49 – 50	51 – 52	
	<sup>*1</sup> 3700	N3000	HT	<sup>*2</sup> <sup>*3</sup> 3R80	3V10	<sup>*3</sup> 3VE0	5501	3450	34PW	35NG	Hose series Size
	—	—	—	—	—	—	—	—	20.0	—	02
	21.0 <sup>*5</sup>	—	—	35.0	70.0	70.0	—	23.0	—	—	03
	19.5 <sup>*5</sup>	28.0	28.0	35.0 <sup>*5</sup>	70.0	70.0	21.0	23.0	19.5	22.0	04
	—	—	—	—	—	—	—	—	—	—	05
	16.0 <sup>*5</sup>	21.0 <sup>*5</sup>	21.0	28.0 <sup>*5</sup>	52.5	52.5	21.0	21.0	16.0	28.0	06
	14.0 <sup>*5</sup>	21.0 <sup>*5</sup>	21.0	25.0 <sup>*5</sup>	—	—	—	—	14.0	28.0	08
	—	17.5	17.5	—	—	—	—	—	—	—	10
	—	—	—	16.0 <sup>*5</sup>	—	—	—	—	10.5	—	12
	—	—	—	14.0	—	—	—	—	10.5	—	16
	-55 – +100	-40 – +100	-40 – +120	-40 – +100	-40 – +66	-40 – +66	-10 – +60	-40 – +80	-30 – +70	-40 – +66	Temp. range (°C)
	Eco-friendly	Flexible	Flexible, for high temp oil	High pressure	Super high pressure (with hose guard)	Super high pressure (with hose guard)	Painting (SUS braid)	Painting, light (conductive resin)	Pure water, chemicals	High pressure gas (conductive resin)	Features
	<ul style="list-style-type: none"> <li>● Industrial vehicle</li> <li>● Hose reel, etc.</li> </ul>	<ul style="list-style-type: none"> <li>● Construction machine</li> <li>● Industrial vehicle</li> <li>● Injection molding machine</li> <li>● Hose reel, etc.</li> </ul>	<ul style="list-style-type: none"> <li>● Construction machine</li> <li>● Industrial vehicle</li> <li>● Injection molding machine</li> <li>● Hose reel, etc.</li> </ul>	<ul style="list-style-type: none"> <li>● Construction machine</li> <li>● Hydraulic press</li> <li>● Ship, etc.</li> </ul>	<ul style="list-style-type: none"> <li>● Hydraulic jack</li> <li>● Pressure bonding machine</li> <li>● Hydraulic tools, etc.</li> </ul>	<ul style="list-style-type: none"> <li>● Hydraulic jack</li> <li>● Pressure bonding machine</li> <li>● Hydraulic tools, etc.</li> </ul>	<ul style="list-style-type: none"> <li>● Airless painting machine, etc.</li> </ul>	<ul style="list-style-type: none"> <li>● Airless painting machine, etc.</li> </ul>	<ul style="list-style-type: none"> <li>● Facility in clean room</li> <li>● Urethane coating</li> <li>● Desalination equipment</li> </ul>	<ul style="list-style-type: none"> <li>● CNG dispenser</li> <li>● CNG compressor</li> </ul>	Application
	○ <b>S</b>	○ <b>S</b>	○ <b>S</b>	○ <b>S</b>	○	○				<b>S</b>	SA
	○ <b>S</b>	○ <b>S</b>	○ <b>S</b>	○ <b>S</b>	○	○			<b>S</b> ⊙	<b>S</b>	SE
	○ <b>S</b>	○	○	○	○	○	○	○			SF
	○										SK
	○	○	○	○							SO
	○			○							SC
	△										SLE
	○	○	○	○							SL
	○	○	○								AE
	○	○	○								AF
	△										AK
				○							A
				○							E
				○							F
											CA
											CE
											CF

## Push-one type

### Campucka



The Campucka coupling enables push-one connection in the hose-coupling assembling. Without any swaging machine, the on-site assembling can be performed easily without fail.

#### Cross-sectional structure diagram

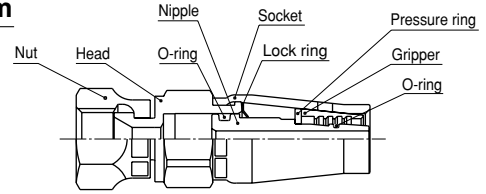

Assembling method  
P.73

## Swaging type

### Swage



The swage coupling is attached to the hose by swaging. The coupling and the hose can be easily swaged (assembled) with a manual assembling tool [Mark10], or a hydraulic assembling machine [Mark9].

Some couplers and hoses have to be assembled in our factory.

#### Cross-sectional structure diagram

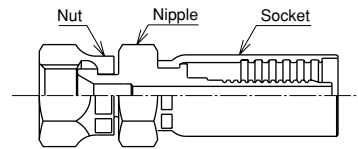

Assembling method  
P.75

## Compression type

### Reusable



The reusable coupling is used to screw in a hose. On-site assembling is possible and the detached coupling is reusable.

#### Cross-sectional structure diagram

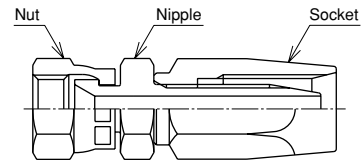

Assembling method  
P.81

# List of hose connection shapes

## Example of part number

# SE-PF-04 - (N30) - (S)

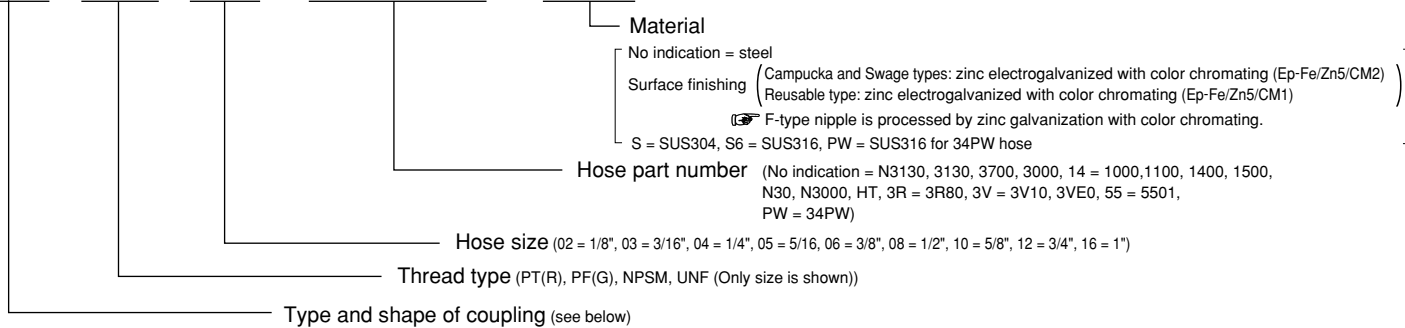

### Tapered male-thread coupling

**SA** (Swage)  
**A** (Reusable)  
**CA** (Campucka)

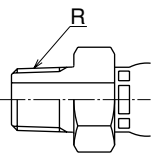

### O-ring port coupling with parallel male-thread

**SO** (Swage)

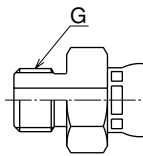

### Parallel male-thread coupling (with 30° female seat)

**SC** (Swage)

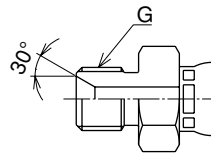

### Parallel female-thread union seat coupling (with 30° female seat)

**SE** (Swage)  
**E** (Reusable)  
**CE** (Campucka)

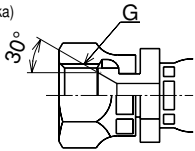

### Parallel female-thread union seat coupling (with 30° male seat)

**SF** (Swage)  
**F** (Reusable)  
**CF** (Campucka)

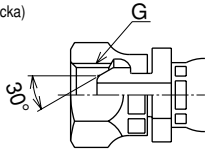

### Unified female-thread union seat coupling (with 37° female seat)

**SK** (Swage)

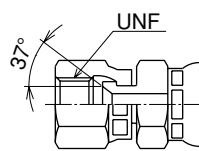

### Unified female-thread ORFS union coupling

**SGS** (Swage)

**Made-to-order**  
 Contact us for details

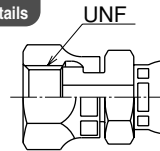

### Parallel female-thread union 90° elbow coupling (with 30° female seat)

**SLE** (Swage)

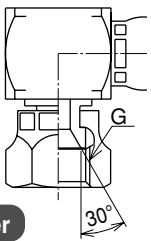

**Made-to-order**

### Parallel female-thread union 90° elbow coupling (with 30° male seat)

**SL** (Swage)

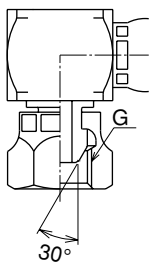

### Unified external-thread union 90° elbow coupling (with 37° female seat)

**SLK** (Swage)

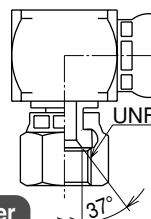

**Made-to-order**  
 Contact us for details

### Unified female-thread ORFS union 90° elbow coupling

**SLG** (Swage)

**Made-to-order**  
 Contact us for details

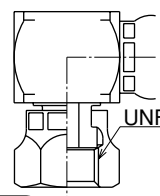

### Parallel female-thread union bend coupling (with 30° female seat)

**AE\*** (Swage)  
**SE** (Swage)

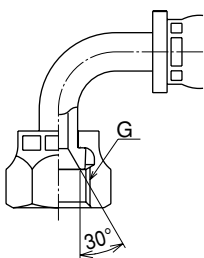

### Parallel female-thread union bend coupling (with 30° male seat)

**AF\*** (Swage)  
**SF** (Swage)

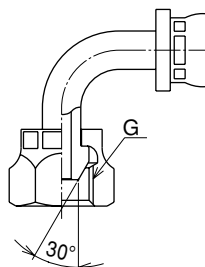

### Unified female-thread union bend coupling (with 37° female seat)

**AK\*** (Swage)

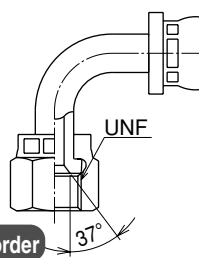

**Made-to-order**

### Unified female-thread ORFS union bend coupling

**AG\*** (Swage)

**Made-to-order**  
 Contact us for details

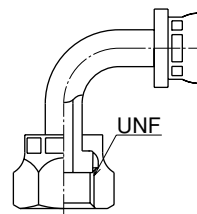

The mark \* at the part number of the union bend indicates the angle and select 45° or 90°.

# [Functional coupling shape]

## Coupling with a simple one-touch connection system

**SJ** (Swage)

Made-to-order  
Contact us for details

### FEATURES

### One-touch connection between hose coupling and adaptor

- Drastic reduction of piping operation time (by 87% in our case)
- Easy piping in a narrow space (enabling compact designs of equipment)
- Operation tools, such as torque wrench, are unnecessary. (Operation reliability improves without torque control.)

Maximum working pressure: 7.0MPa

### Structure

#### Before connection

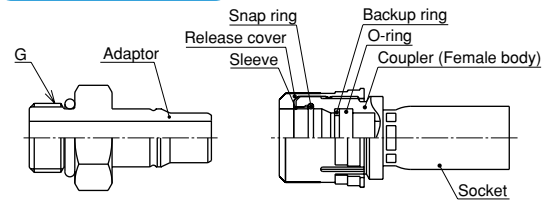

#### After connection

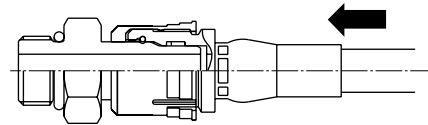

## Swivel coupling with parallel male-thread O-ring port

**AWO** (Swage)

Made-to-order  
Contact us for details

### FEATURES

### Single operation accomplishes tightening screw when piping, because no adaptor is needed.

- Low profile is possible because of no adaptor.
- Swivel allows direction change after the piping.
- Swivel relaxes hose twisting.

Working temperature range: -25 to 100°C  
Maximum working pressure: 10.5MPa

### Structure

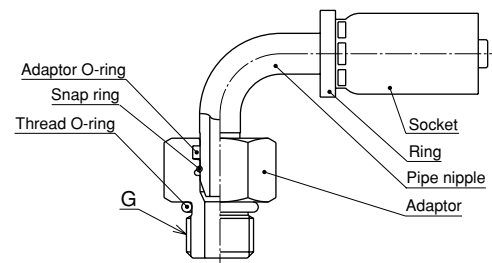

## Coupling with steel-pipe bite function

**SB** (Swage)

Made-to-order  
Contact us for details

### FEATURES

### This single coupling connects a steel pipe and hose.

- Reduction of operation time
- Improvement of leakage reliability due to reduction of the number of connections.
- Maintenance cost can be cut because the intermediate connections are not necessary.
- Downsized connection part
- Total cost cut of connection part
- Realization of high reliability of bite couplings through collaboration with Ihara Science Corporation.

### Comparison with the conventional connection method

#### Conventional connection method (bite coupling + hose coupling)

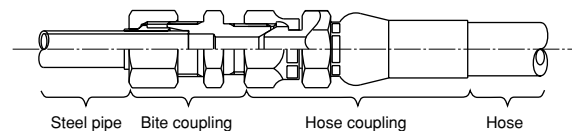

#### SB coupling

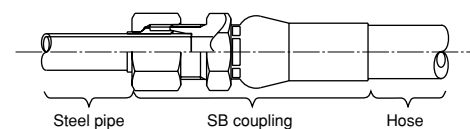

## Integration of Q.D.C. and hose coupling

**SQ** (Swage)

**Made-to-order**  
Contact us for details

**FEATURES**

**Integration of Q.D.C. and hose coupling saves space**

- Reduction of operation time when piping
- Space-saving

Working temperature range: -30 to 93°C

☞ It is possible to use the coupler or nipple side in combination with Q.D.C.

### Structure

#### Before connection

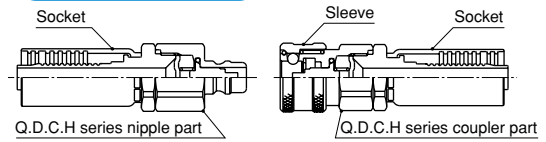

#### After connection

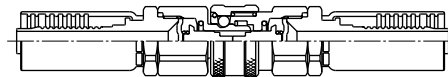



# LF70 Series

## LF70

### Features

- Improved flexibility by 15-25% (compared to our other equivalent types)
- Short total length of coupling enables compact piping.

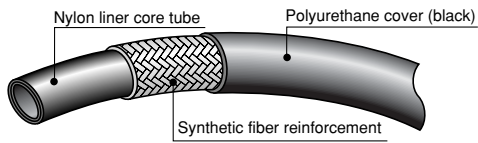

Part No.	Size No.	Size			Max. working press. (MPa)	Max. impact press. (MPa)	Min. destruction press. (MPa)	Min. bending radius (mm)	Weight (g/m)	Suitable coupling type
		I.D. (in.)	I.D. (mm)	O.D. (mm)						
LF70-04	04	1/4	6.4	10.3	7.0	8.8	28.0	27	60	Swage
LF70-06	06	3/8	9.5	13.9	7.0	8.8	28.0	45	90	

- Appropriate fluid: mineral general operating oil
- Working temperature range: -40 to +100°C
- Length in a unit package: 100m

## [Swage type]

(For LF70)

## SA

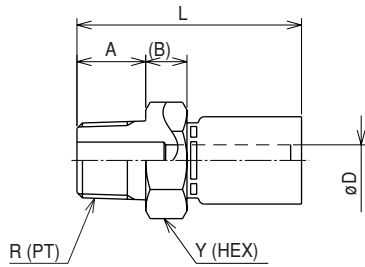

Part No.	Size No.	R	A	B	Min. I.D. øD	L	Y (HEX)	Weight (g)	Pusher	Die
SA-R-04-07	04	1/4	13	8.5	3.5	42	19	35	PSA-04	SP07-04
SA-R-06-07	06	3/8	15	9.0	6.8	49	22	65	PSA-06	SP07-06

- Material: steel
- Surface finishing: zinc electro-galvanized with color chromating (Ep-Fe/Zn 5/CM2)
- Adaptor: 030, 130

## SE

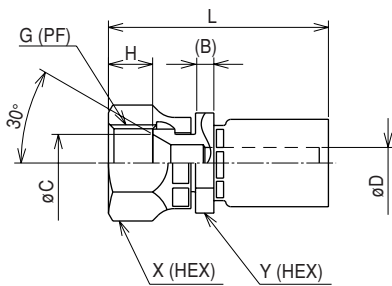

Part No.	Size No.	G	B	C	Min. I.D. øD	H	L	X (HEX)	Y (HEX)	Weight (g)	Pusher	Die
SE-G-04-07	04	1/4	4.0	9.5	3.5	8.2	41	19	17	45	PSE-14-04	SP07-04
SE-G-06-07	06	3/8	4.0	12.5	6.8	9.7	48	22	19	65	PSE-14-06	SP07-06

- Material: steel
- Surface finishing: zinc electro-galvanized with color chromating (Ep-Fe/Zn 5/CM2)
- Adaptor: 010, 045, 090, 150, 020, 025, 064, 069, 030, D70, D74, D79

## SF

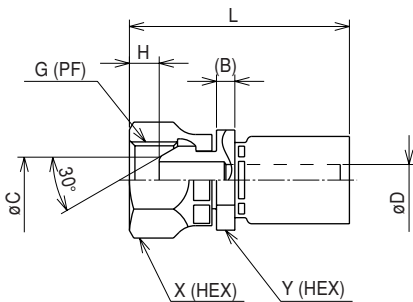

Part No.	Size No.	G	B	C	Min. I.D. øD	H	L	X (HEX)	Y (HEX)	Weight (g)	Pusher	Die
SF-G-04-07	04	1/4	4.0	7.5	3.5	5.5	41	19	17	45	PSE-14-04	SP07-04
SF-G-06-07	06	3/8	4.0	10.0	6.8	6.5	48	22	19	65	PSE-14-06	SP07-06

- Material: steel
- Surface finishing: zinc electro-galvanized with color chromating (Ep-Fe/Zn 5/CM2)
- Adaptor: 110, 145, 190, 130, C70, C74, C79

[Swage type]

(For LF70)

# AE45

Made-to-order

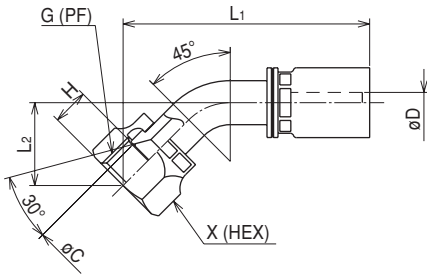

Part No.	Size No.	G	C	Min. I.D. øD	H	L <sub>1</sub>	L <sub>2</sub>	X (HEX)	Weight (g)	Pusher	Die
★ AE45-G-04-07	04	1/4	9.0	3.2	8.2	54	18	19	49	PFB-01+PA-04-07	SP07-04
★ AE45-G-06-07	06	3/8	12.0	5.6	9.7	70	25	22	82	PFB-01+PA-06	SP07-06

- Material: steel
- Surface finishing: zinc electro-galvanized with color chromating (Ep-Fe/Zn 5/CM2)
- Adaptor: 010, 045, 090, 150, 020, 025, 064, 069, 030, D70, D74, D79
- ★ Made-to-order

# AE90

Made-to-order

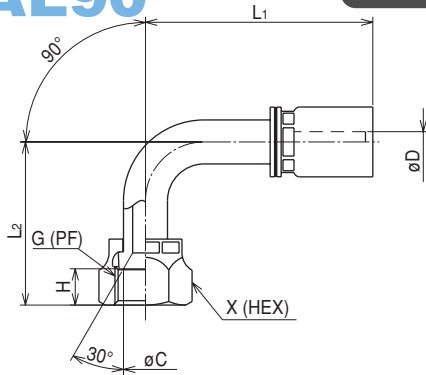

Part No.	Size No.	G	C	Min. I.D. øD	H	L <sub>1</sub>	L <sub>2</sub>	X (HEX)	Weight (g)	Pusher	Die
★ AE90-G-04-07	04	1/4	9.0	3.2	8.2	47	33	19	52	PFB-01+PA-04-07	SP07-04
★ AE90-G-06-07	06	3/8	12.0	5.6	9.7	62	45	22	93	PFB-01+PA-06	SP07-06

- Material: steel
- Surface finishing: zinc electro-galvanized with color chromating (Ep-Fe/Zn 5/CM2)
- Adaptor: 010, 045, 090, 150, 020, 025, 064, 069, 030, D70, D74, D79
- ★ Made-to-order

# AF45

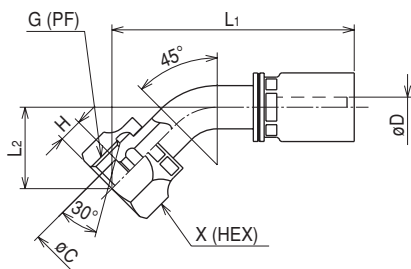

Part No.	Size No.	G	C	Min. I.D. øD	H	L <sub>1</sub>	L <sub>2</sub>	X (HEX)	Weight (g)	Pusher	Die
AF45-G-04-07	04	1/4	7.0	3.2	5.5	55	19	19	50	PFB-01+PA-04-07	SP07-04
AF45-G-06-07	06	3/8	10.0	5.6	6.5	67	23	22	82	PFB-01+PA-06	SP07-06

- Material: steel
- Surface finishing: zinc electro-galvanized with color chromating (Ep-Fe/Zn 5/CM2)
- Adaptor: 110, 145, 190, 130, C70, C74, C79

# AF90

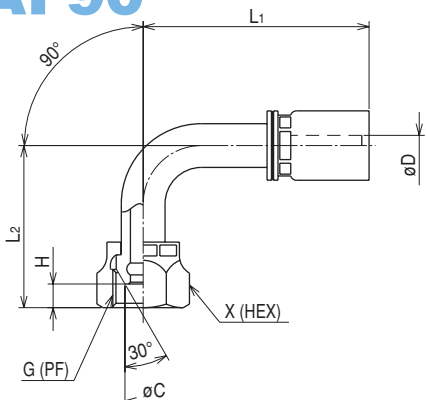

Part No.	Size No.	G	C	Min. I.D. øD	H	L <sub>1</sub>	L <sub>2</sub>	X (HEX)	Weight (g)	Pusher	Die
AF90-G-04-07	04	1/4	7.0	3.2	5.5	47	33	19	54	PFB-01+PA-04-07	SP07-04
AF90-G-06-07	06	3/8	10.0	5.6	6.5	61	45	22	95	PFB-01+PA-06	SP07-06

- Material: steel
- Surface finishing: zinc electro-galvanized with color chromating (Ep-Fe/Zn 5/CM2)
- Adaptor: 110, 145, 190, 130, C70, C74, C79

Hydraulic  
Hose

Airtless-  
painting  
Hose

Clean  
Hose

Natural-Gas  
Hose

Adaptor

Hose Guard  
Part, Specially-  
Treated Part

Assembling  
Machine,  
Jig, Tool

Hose  
Assembling  
Method

Technical  
Document

Reference  
Document

# 1000-1100-1400-1500 Series

## 1000

### Features

- Small outer diameter
- Light
- Campucka coupling can be used

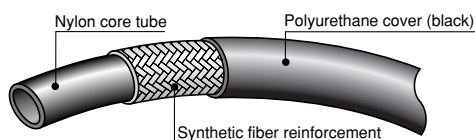

Part No.	Size			Max. working press. (MPa)	Max. impact press. (MPa)	Min. destruction press. (MPa)	Min. bending radius (mm)	Weight (g/m)	Coupling	
	Size No.	I.D.								O.D.
		(in.)	(mm)	(mm)						
1000-04	04	1/4	6.3	10.4	10.5	13.2	42.0	40	64	Campucka Swage
1000-06	06	3/8	9.5	14.0	10.5	13.2	42.0	60	90	
1000-08	08	1/2	12.7	17.4	10.5	13.2	42.0	80	131	

- Appropriate fluid: mineral general operating oil
- Working temperature range: -40 to +100°C
- Length in a unit package: 100m

## 1100

### Features

- Outer wire reinforcement prevents the cutting powder

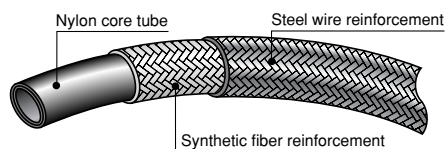

Part No.	Size			Max. working press. (MPa)	Max. impact press. (MPa)	Min. destruction press. (MPa)	Min. bending radius (mm)	Weight (g/m)	Coupling	
	Size No.	I.D.								O.D.
		(in.)	(mm)	(mm)						
1100-04	04	1/4	6.3	11.1	10.5	13.2	42.0	40	150	Swage
1100-06	06	3/8	9.5	15.1	10.5	13.2	42.0	60	220	
1100-08	08	1/2	12.7	18.8	10.5	13.2	42.0	80	300	

- Appropriate fluid: mineral general operating oil
- Working temperature range: -40 to +100°C
- Length in a unit package: 100m

## 1400

### Features

- Small outer diameter
- Light
- Kampucka connector can be used

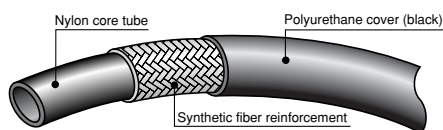

Part No.	Size			Max. working press. (MPa)	Max. impact press. (MPa)	Min. destruction press. (MPa)	Min. bending radius (mm)	Weight (g/m)	Coupling	
	Size No.	I.D.								O.D.
		(in.)	(mm)	(mm)						
1400-04	04	1/4	6.3	10.4	14.0	17.5	56.0	40	64	Campucka Swage
1400-06	06	3/8	9.5	14.0	14.0	17.5	56.0	60	90	

- Appropriate fluid: mineral general operating oil
- Working temperature range: -40 to +100°C
- Length in a unit package: 100m

## 1500

### Features

- Small outer diameter
- Light

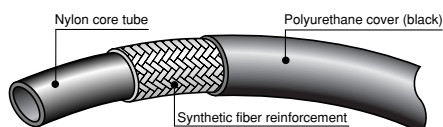

Part No.	Size			Max. working press. (MPa)	Max. impact press. (MPa)	Min. destruction press. (MPa)	Min. bending radius (mm)	Weight (g/m)	Coupling	
	Size No.	I.D.								O.D.
		(in.)	(mm)	(mm)						
1500-03	03	3/16	5.1	8.8	15.0	18.8	60.0	20	45	Swage

- Appropriate fluid: mineral general operating oil
- Working temperature range: -40 to +100°C
- Length in a unit package: 100m

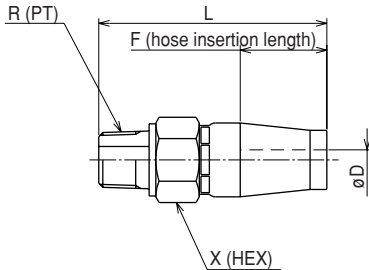

**[Campucka] Hydraulic push-one coupling****(For 1000, 1400)****CA**

Part No.	R	Min. I.D. øD	F	L	X	Weight (g)
CA-R-04-14L	1/4	3.5	26.0	60	19	70
CA-R-06-14L	3/8	6.0	29.0	68	22	100
CA-R-08-14L	1/2	9.0	35.0	77	27	170

△Caution: Handle with care not to drop couplings as an inner nipple could be self locked by pushing-out action to inlet of coupling.

- Material: steel
- Surface finishing: zinc electro-galvanized with color chromating (Ep-Fe/Zn 5/CM2)
- Working temperature range: -20 to +100°C
- Adaptor: 030, 130

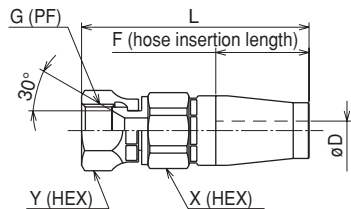
**CE**

Part No.	G	Min. I.D. øD	F	L	X	Y	Weight (g)
CE-G-04-14L	1/4	3.5	26.0	64	19	19	85
CE-G-06-14L	3/8	6.0	29.0	72	22	22	115
CE-G-08-14L	1/2	9.0	35.0	83	27	27	205

△Caution: Handle with care not to drop couplings as an inner nipple could be self locked by pushing-out action to inlet of coupling.

- Material: steel
- Surface finishing: zinc electro-galvanized with color chromating (Ep-Fe/Zn 5/CM2)
- Working temperature range: -20 to +100°C
- Adaptor: 010, 045, 090, 150, 020, 025, 064, 069, 030, D70, D74, D79

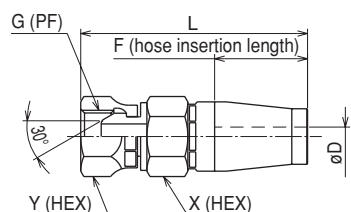
**CF**

Part No.	G	Min. I.D. øD	F	L	X	Y	Weight (g)
CF-G-04-14L	1/4	3.5	26.0	64	19	19	85
CF-G-06-14L	3/8	6.0	29.0	72	22	22	115
CF-G-08-14L	1/2	9.0	35.0	83	27	27	205

△Caution: Handle with care not to drop couplings as an inner nipple could be self locked by pushing-out action to inlet of coupling.

- Material: steel
- Surface finishing: zinc electro-galvanized with color chromating (Ep-Fe/Zn 5/CM2)
- Working temperature range: -20 to +100°C
- Adaptor: 110, 145, 190, 130, C70, C74, C79

**Features of Campucka and assembly mechanism****Assembling method**  
P.73**1. Push-one connection**

- Reduction of operation time (half that of our conventional product)
- Specialized swaging tool is not necessary. (Easy handling)
- Best for on-site length adjustment.
- Convenient for emergency repair.

**4. Nipple stop mechanism**

- Ratchet mechanism of our original lock ring is employed.
- Steady performance even for movable piping.
- Pressure variation is accommodated.

**2. Detachable hose**

- Hose is detachable for length adjustment when piping.
  - Detachable tool is available.
- △Caution: Cannot be detached after pressurization.

**3. Correcting hose's twisted direction**

- It is possible to correct the twisted direction of a hose.
- △Caution: Cannot be detached after pressurization.

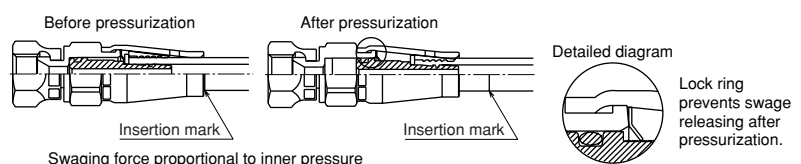
**Campucka assembly mechanism**

△Caution: Handle with care not to drop couplings as an inner nipple could be self locked by pushing-out action to inlet of coupling.

[Swage]

(For 1000, 1100, 1400, 1500)

SA

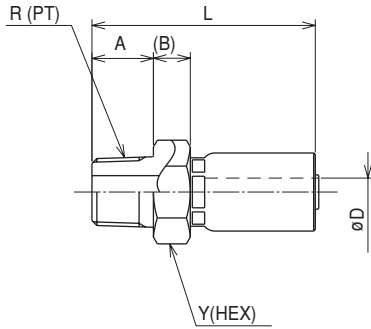

Part No.	Size No.	R	A	B	Min. I.D. øD	L	Y (HEX)	Wt. (g)	Pusher	Die
SA-PT-03-14	03	1/4	13	8.5	3.0	44	19	40	PSA-03	SP14-03
SA-PT-04-14	04	1/4	13	8.5	3.5	50	19	43	PSA-04	SP14-04
SA-PT-06-14	06	3/8	15	9.0	6.8	54	22	72	PSA-06	SP14-06
SA-PT-08-14	08	1/2	18	10.0	9.5	61	27	115	PSA-08	SP14-08 SP10-08

- Material: steel
- Surface finishing: zinc electro-galvanized with color chromating (Ep-Fe/Zn 5/CM2)
- Adaptor: 030, 130
- \* Use SP-14-08 for 1000-08 and SP-10-08 for 1100-08.

Stainless type

Part No.	Size No.	R	A	B	Min. I.D. øD	L	Y (HEX)	Wt. (g)	Pusher	Die	
										First	Second
SA-PT-04-14-S	04	1/4	13	8.5	3.5	50	19	43	PSA-04	SPH-03	SP14-04
SA-PT-06-14-S	06	3/8	15	9.0	6.8	54	22	72	PSA-06	SP3-05-1-ST	SP14-06
SA-PT-08-14-S	08	1/2	18	10.0	9.5	61	27	115	PSA-08	SPH-06-1-ST	SP14-08

- Material: steel
- Suitable adaptor: 030, 130

SE

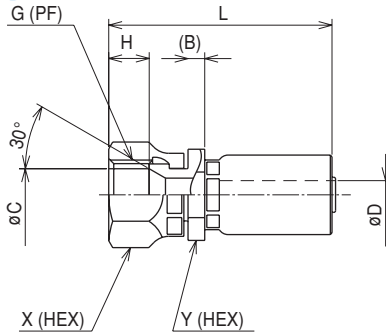

Part No.	Size No.	G	B	C	Min. I.D. øD	H	L	X (HEX)	Y (HEX)	Wt. (g)	Pusher	Die
SE-PF-03-14	03	1/4	4.0	9.5	3.0	8.0	44	19	17	42	PSE14-03	SP14-03
SE-PF-04-14	04	1/4	4.0	9.5	3.5	8.0	49	19	17	55	PSE14-04	SP14-04
SE-PF-06-14	06	3/8	4.0	12.5	6.8	9.5	53	22	19	71	PSE14-06	SP14-06
SE-PF-08-14	08	1/2	4.5	16.0	9.5	12.0	61	27	24	125	PSE14-08	SP14-08 SP10-08

- Material: steel
- Surface finishing: zinc electro-galvanized with color chromating (Ep-Fe/Zn 5/CM2)
- Adaptor: 010, 045, 090, 150, 020, 025, 064, 069, 030, D70, D74, D79
- \* Use SP-14-08 for 1000-08 and SP-10-08 for 1100-08.

Stainless type

Part No.	Size No.	G	B	C	Min. I.D. øD	H	L	X (HEX)	Y (HEX)	Wt. (g)	Pusher	Die	
												First	Second
SE-PF-04-14-S	04	1/4	4.0	9.5	3.5	8.0	49	19	17	55	PSE-14-04	SPH-03	SP14-04
SE-PF-06-14-S	06	3/8	4.0	12.5	6.8	9.5	53	22	19	71	PSE-14-06	SP3-05-1-ST	SP14-06
SE-PF-08-14-S	08	1/2	4.5	16.0	9.5	12.0	61	27	24	125	PSE-14-08	SPH-06-1-ST	SP14-08

- Material: steel
- Suitable adaptor: 010, 045, 090, 150, 020, 025, 064, 069, 030, D70, D74, D79

SF

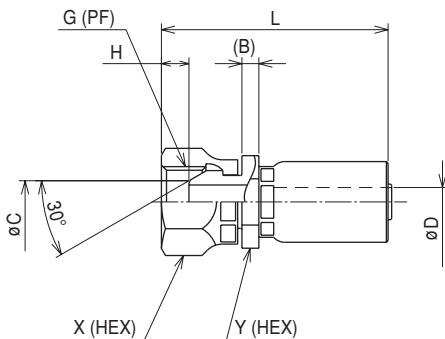

Part No.	Size No.	G	B	C	Min. I.D. øD	H	L	X (HEX)	Y (HEX)	Wt. (g)	Pusher	Die
SF-PF-03-14	03	1/4	4.0	7.5	3.0	5.5	44	19	17	44	PSE14-03	SP14-03
SF-PF-04-14	04	1/4	4.0	7.5	3.5	5.5	49	19	17	56	PSE14-04	SP14-04
SF-PF-06-14	06	3/8	4.0	10.0	6.8	6.5	53	22	19	75	PSE14-06	SP14-06
SF-PF-08-14	08	1/2	4.5	13.2	9.5	9.0	61	27	24	125	PSE14-08	SP14-08 SP10-08

- Material: steel
- Surface finishing: zinc electro-galvanized with color chromating (Ep-Fe/Zn 5/CM2)
- Adaptor: 110, 145, 190, 130, C70, C74, C79
- \* Use SP-14-08 for 1000-08 and SP-10-08 for 1100-08.

Stainless type

Part No.	Size No.	G	B	C	Min. I.D. øD	H	L	X (HEX)	Y (HEX)	Wt. (g)	Pusher	Die	
												First	Second
SF-PF-04-14-S	04	1/4	4.0	7.5	3.5	5.5	49	19	17	56	PSE-14-04	SPH-03	SP14-04
SF-PF-06-14-S	06	3/8	4.0	10.0	6.8	6.5	53	22	19	75	PSE-14-06	SP3-05-1-ST	SP14-06
SF-PF-08-14-S	08	1/2	4.5	13.2	9.5	9.0	61	27	24	125	PSE-14-08	SPH-06-1-ST	SP14-08

- Material: steel
- Adaptor: 110, 145, 190, 130, C70, C74, C79

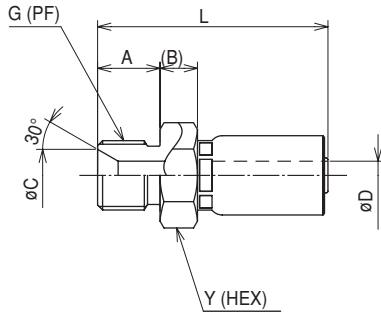
**[Swage]****(For 1000, 1100, 1400, 1500)****SC**

Part No.	Size No.	G	A	B	C	øD	L	Y (HEX)	Wt. (g)	Pusher	Die
SC-PF-04-14	04	1/4	14	8.5	9.5	3.5	51	19	43	PSA-04	SP14-04
SC-PF-06-14	06	3/8	15	9.0	12.5	6.8	54	22	72	PSA-06	SP14-06
SC-PF-08-14	08	1/2	18	10.0	18.0	9.5	61	27	115	PSA-08	* SP14-08 SP10-08

- Material: steel
- Surface finishing: zinc electro-galvanized with color chromating (Ep-Fe/Zn 5/CM2)
- Adaptor: 060
- \* Use SP-14-08 for 1000-08 and SP-10-08 for 1100-08.

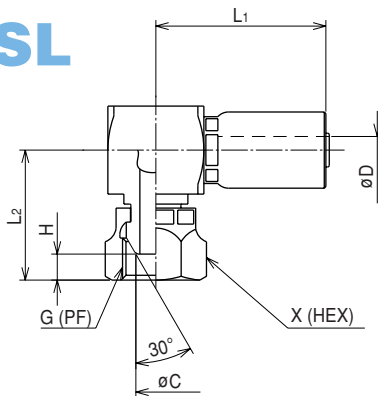
**SL**

Part No.	Size No.	G	C	Min. I.D. øD	H	L <sub>1</sub>	L <sub>2</sub>	X (HEX)	Wt. (g)	Pusher	Die
SL-PF-04-14	04	1/4	7.5	3.5	5.5	39	28	19	120	PSL-04	SP14-04
SL-PF-06-14	06	3/8	10.0	6.8	6.5	42	33	22	160	PSL-06	SP14-06
SL-PF-08-14	08	1/2	13.2	9.5	9.0	47	37	27	250	PSL-08	* SP14-08 SP10-08

- Material: steel
- Surface finishing: zinc electro-galvanized with color chromating (Ep-Fe/Zn 5/CM2)
- Adaptor: 110, 145, 190, 130, C70, C74, C79
- \* Use SP-14-08 for 1000-08 and SP-10-08 for 1100-08.

[Swage]

(For 1000, 1100, 1400)

## AE45

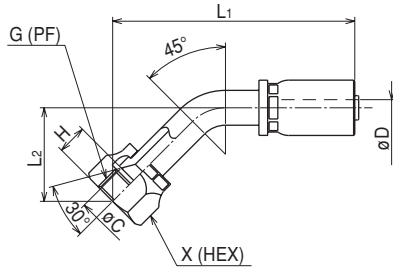

Part No.	Size No.	G	C	Min. I.D. øD	H	L <sub>1</sub>	L <sub>2</sub>	X (HEX)	Wt. (g)	Pusher	Die
AE45-G-04-14	04	1/4	9.0	3.2	8.0	61	18	19	57	PFB-01+PA-04	SP14-04
AE45-G-06-14	06	3/8	12.0	5.6	9.5	74	25	22	90	PFB-01+PA-06	SP14-06
AE45-G-08-14	08	1/2	15.5	8.7	12.0	87	29	27	143	PFB-01+PA-08	* SP14-08 SP10-08

- Material: steel
- Surface finishing: zinc electro-galvanized with color chromating (Ep-Fe/Zn 5/CM2)
- Adaptor: 010, 045, 090, 150, 020, 025, 064, 069, 030, D70, D74, D79
- \* Use SP-14-08 for 1000-08 and SP-10-08 for 1100-08.

## AE90

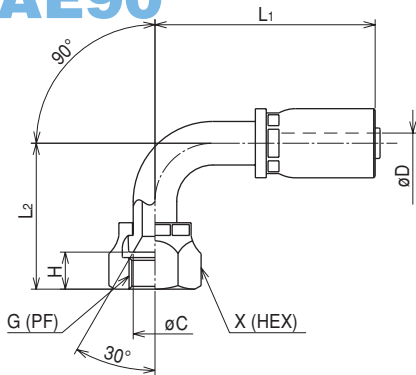

Part No.	Size No.	G	C	Min. I.D. øD	H	L <sub>1</sub>	L <sub>2</sub>	X (HEX)	Wt. (g)	Pusher	Die
AE90-G-04-14	04	1/4	9.0	3.2	8.0	51	33	19	59	PFB-01+PA-04	SP14-04
AE90-G-06-14	06	3/8	12.0	5.6	9.5	61	45	22	98	PFB-01+PA-06	SP14-06
AE90-G-08-14	08	1/2	15.5	8.7	12.0	68	52	27	153	PFB-01+PA-08	* SP14-08 SP10-08

- Material: steel
- Surface finishing: zinc electro-galvanized with color chromating (Ep-Fe/Zn 5/CM2)
- Adaptor: 010, 045, 090, 150, 020, 025, 064, 069, 030, D70, D74, D79
- \* Use SP-14-08 for 1000-08 and SP-10-08 for 1100-08.

## AF45

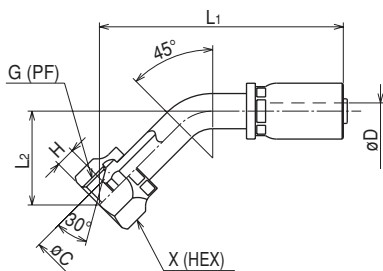

Part No.	Size No.	G	C	Min. I.D. øD	H	L <sub>1</sub>	L <sub>2</sub>	X (HEX)	Wt. (g)	Pusher	Die
AF45-G-04-14	04	1/4	7.0	3.2	5.5	63	19	19	58	PFB-01+PA-04	SP14-04
AF45-G-06-14	06	3/8	10.0	5.6	6.5	72	23	22	90	PFB-01+PA-06	SP14-06
AF45-G-08-14	08	1/2	14.0	8.7	9.0	88	30	27	147	PFB-01+PA-08	* SP14-08 SP10-08

- Material: steel
- Surface finishing: zinc electro-galvanized with color chromating (Ep-Fe/Zn 5/CM2)
- Adaptor: 110, 145, 190, 130, C70, C74, C79
- \* Use SP-14-08 for 1000-08 and SP-10-08 for 1100-08.

## AF90

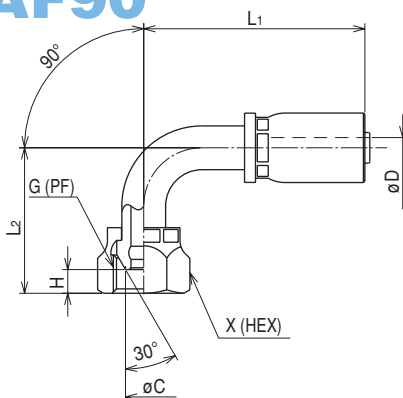

Part No.	Size No.	G	C	Min. I.D. øD	H	L <sub>1</sub>	L <sub>2</sub>	X (HEX)	Wt. (g)	Pusher	Die
AF90-G-04-14	04	1/4	7.0	3.2	5.5	51	33	19	61	PFB-01+PA-04	SP14-04
AF90-G-06-14	06	3/8	10.0	5.6	6.5	61	45	22	100	PFB-01+PA-06	SP14-06
AF90-G-08-14	08	1/2	14.0	8.7	9.0	68	52	27	156	PFB-01+PA-08	* SP14-08 SP10-08

- Material: steel
- Surface finishing: zinc electro-galvanized with color chromating (Ep-Fe/Zn 5/CM2)
- Adaptor: 110, 145, 190, 130, C70, C74, C79
- \* Use SP-14-08 for 1000-08 and SP-10-08 for 1100-08.

[Swage]

(For 1000, 1100, 1400)

SK

Made-to-order

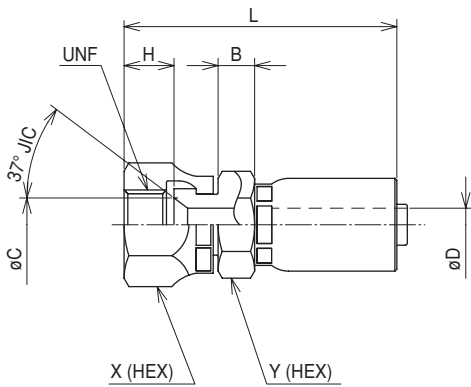

Part No.	Size No.	UNF	B	C	øD	H	L	X (HEX)	Y (HEX)	Wt. (g)	Pusher	Die
★ SK-7/16-04-14	04	7/16-20	6.5	7.5	3.5	9.0	51	19	17	58	PSK-04H	SP14-04
★ SK-9/16-06-14	06	9/16-18	7.5	11.0	6.8	10.0	57	22	19	82	PSK-06H	SP14-06
★ SK-3/4-08-14	08	3/4-16	4.5	14.5	9.5	11.5	57	27	22	105	PSE-14-08	SP14-08 SP10-08

■ Material: steel

■ Surface finishing: zinc electro-galvanized with color chromating (Ep-Fe/Zn 5/CM2)

\* Use SP-14-08 for 1000-08 and SP-10-08 for 1100-08.

★ Made-to-order

AK45

Made-to-order

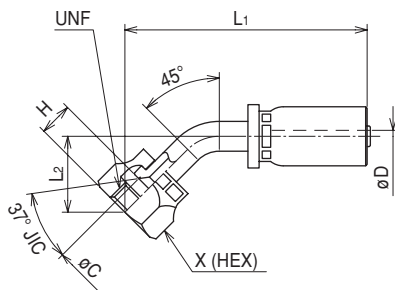

Part No.	Size No.	UNF	C	Min. I.D. øD	H	L1	L2	X (HEX)	Wt. (g)	Pusher	Die
★ AK45-7/16-04-14-C	04	7/16-20	7.5	3.2	9.0	70	27	19	57	PFB-01+PA-04	SP14-04
★ AK45-9/16-06-14-C	06	9/16-18	11.0	5.6	10.0	91	39	22	90	PFB-01+PA-06	SP14-06
★ AK45-3/4-08-14-C	08	3/4-16	14.5	8.7	12.0	98	40	27	143	PFB-01+PA-08	SP14-08 SP10-08

■ Material: steel

■ Surface finishing: zinc electro-galvanized with color chromating (Ep-Fe/Zn 5/CM2)

\* Use SP-14-08 for 1000-08 and SP-10-08 for 1100-08.

★ Made-to-order

AK90

Made-to-order

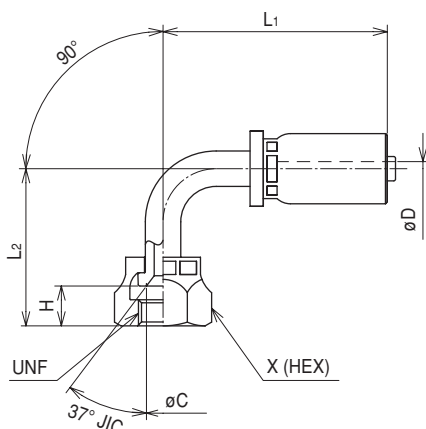

Part No.	Size No.	UNF	C	Min. I.D. øD	H	L1	L2	X (HEX)	Wt. (g)	Pusher	Die
★ AK90-7/16-04-14-C	04	7/16-20	7.5	3.2	9.0	51	36	19	59	PFB-01+PA-04	SP14-04
★ AK90-9/16-06-14-C	06	9/16-18	11.0	5.6	10.0	61	40	22	98	PFB-01+PA-06	SP14-06
★ AK90-3/4-08-14-C	08	3/4-16	14.5	8.7	12.0	68	57	27	153	PFB-01+PA-08	SP14-08 SP10-08

■ Material: steel

■ Surface finishing: zinc electro-galvanized with color chromating (Ep-Fe/Zn 5/CM2)

\* Use SP-14-08 for 1000-08 and SP-10-08 for 1100-08.

★ Made-to-order



# 1000 (light gray) series

## 1000 (light gray)

### Features

- Slim, light
- Campucka compatible

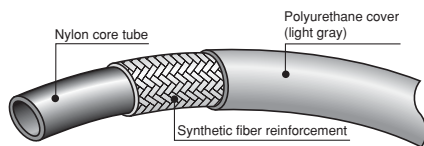

Part No.	Size No.	Size			Max. working press. (MPa)	Max. impact press. (MPa)	Min. destruction press. (MPa)	Min. bending radius (mm)	Weight (g/m)	Coupling
		I.D. (in.)	I.D. (mm)	O.D. (mm)						
1000-04-LGY	04	1/4	6.3	10.4	10.5	13.2	42.0	40	64	Campucka Swage
1000-06-LGY	06	3/8	9.5	14.0	10.5	13.2	42.0	60	90	
1000-08-LGY	08	1/2	12.7	17.4	10.5	13.2	42.0	80	131	

△ Caution: If you use Campucka, the maximum working pressure for Campucka must be applied.

● Appropriate fluid: mineral general operating oil

● Working temperature range: -40 to +100°C

☞ If you use Campucka, the working temperature range for Campucka must be applied.

● Length in a unit package: 100m

☞ Suitable hose coupling is the same as that for the 1000 series.

☞ Color code (-LGY) is appended to part Nos. "LGY" stands for light gray.

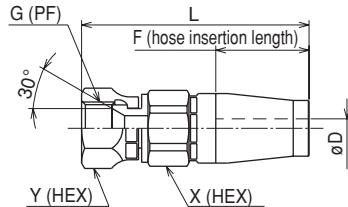
**[Campucka] Hydraulic push-in coupling****(For 1000 (light gray))****CE**

Part No.	G	Min. I.D. øD	F	L	X	Y	Weight (g)
CE-G-04-14L	1/4	3.5	26.0	64	19	19	85
CE-G-06-14L	3/8	6.0	29.0	72	22	22	115
CE-G-08-14L	1/2	9.0	35.0	83	27	27	205

△ Caution: If you use Campucka, the maximum working pressure for Campucka must be applied.  
 △ Caution: Handle with care not to drop couplings as an inner nipple could be self locked by pushing-out action to inlet of coupling.

- Material: steel
- Surface finishing: zinc electro-galvanized with color chromating (Ep-Fe/Zn 5/CM2)
- Maximum working pressure: 10.5MPa
- Working temperature range: -20 to +100°C
- Adaptor: 110, 145, 190, 130, C70, C74, C79

**Features of Campucka and assembly mechanism****Assembling method**  
P.73**1. Push-one connection**

- Reduction of operation time (half that of our conventional product)
- Specialized swaging tool is not necessary. (Easy handling)
- Best for on-site length adjustment.
- Convenient for emergency repair.

**4. Nipple stop mechanism**

- Ratchet mechanism of our original lock ring is employed.
- Steady performance even for movable piping.
- Pressure variation is accommodated.

**2. Detachable hose**

- Hose is detachable for length adjustment when piping.
  - Detachable tool is available.
- △ Caution: Cannot be detached after pressurization.

**3. Correcting hose's twisted direction**

- It is possible to correct the twisted direction of a hose.
- △ Caution: Cannot be detached after pressurization.

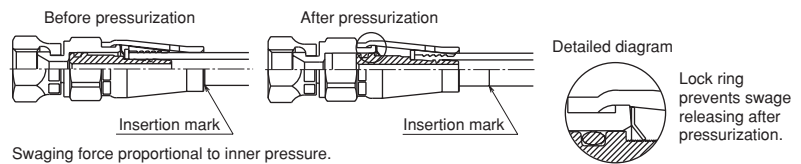
**Campucka assembly mechanism**

△ Caution: Handle with care not to drop couplings as an inner nipple could be self locked by pushing-out action to inlet of coupling.

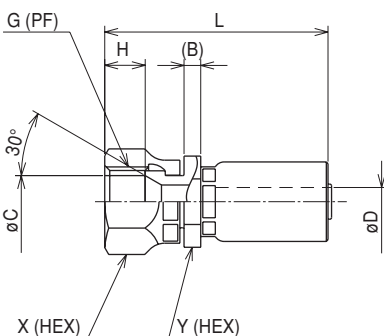
**[Swage]****SE**

Part No.	Size No.	G	B	C	Min. I.D. øD	H	L	X (HEX)	Y (HEX)	Wt. (g)	Pusher	Die
SE-PF-04-14	04	1/4	4.0	9.5	3.5	8.0	49	19	17	55	PSE14-04	SP14-04
SE-PF-06-14	06	3/8	4.0	12.5	6.8	9.5	53	22	19	71	PSE14-06	SP14-06
SE-PF-08-14	08	1/2	4.5	16.0	9.5	12.0	61	27	24	125	PSE14-08	SP14-08

- Material: steel
- Surface finishing: zinc electro-galvanized with color chromating (Ep-Fe/Zn 5/CM2)
- Adaptor: 010, 045, 090, 150, 020, 025, 064, 069, 030, D70, D74, D79
- ☞ Applicable hose couplings are the same as those for 1000 series.

# F3130 (light gray) series

## F3130

### Features

- Flexible and tough
- High abrasion resistance
- Campucka (for F3130)

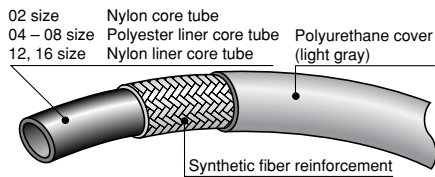

Part No.	Size No.	Size			Max. working press. (MPa)	Max. impact press. (MPa)	Min. destruction press. (MPa)	Min. bending radius (mm)	Weight (g/m)	Coupling
		I.D. (in.)	I.D. (mm)	O.D. (mm)						
F3130-02-LGY	02	1/8	3.6	8.3	20.0	25.0	72.0	15	45	Swage Campucka
F3130-04-LGY	04	1/4	6.3	12.5	19.5	24.4	77.0	40	105	
F3130-06-LGY	06	3/8	9.5	16.4	16.0	20.0	63.0	50	150	
F3130-08-LGY	08	1/2	12.7	20.3	14.0	17.4	56.0	75	210	Swage
F3130-12-LGY	12	3/4	19.0	26.6	9.0	11.3	35.0	130	290	
F3130-16-LGY	16	1	25.4	33.4	7.0	8.8	28.0	165	400	

△ Caution: If you use Campucka, the maximum working pressure for Campucka must be applied.

- Appropriate fluid: mineral general operating oil
- Working temperature range: -40 to +100°C
- 👁️ If you use Campucka, the working temperature range for Campucka must be applied.
- Length in a box: 100 m for sizes 02, 04, 06, 08, and 50 m for sizes 12, 16.
- 👁️ Hose coupling is the same as that for the N3130 and 3130 series.
- 👁️ Color code (-LGY) is appended to part Nos. "LGY" stands for light gray.

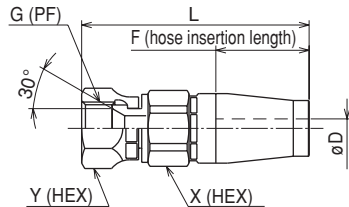
**[Campucka] Hydraulic push-one coupling****(For F3130 (light gray))****CE (for F3130 series)**

Part No.	Size No.	G	Min. I.D. øD	F	L	X	Y	Weight (g)
CE-G-02L	02	1/8	1.5	22.5	62	14	14	44
CE-G-04-F31-10L	04	1/4	3.5	28	74	19	19	105
CE-G-06-F31-10L	06	3/8	6.3	34	84	22	22	150
CE-G-08-F31-10L	08	1/2	9.4	37	92	27	27	225

△ Caution: Handle with care not to drop couplings as an inner nipple could be self locked by pushing-out action to inlet of coupling.

- Material: steel
- Surface finishing: zinc electro-galvanized with color chromating (Ep-Fe/Zn 5/CM2)
- Maximum working pressure: 10.5MPa (CE-G-02L: 20.0MPa)
- Working temperature range: -20 to +100°C
- Adaptor: 010, 045, 090, 150, 020, 025, 064, 069, 030, D70, D74, D79

**Features of Campucka and assembly mechanism****Assembling method**  
P.73**1. Push-one connection**

- Reduction of operation time (half that of our conventional product)
- Specialized swaging tool is not necessary. (Easy handling)
- Best for on-site length adjustment.
- Convenient for emergency repair.

**4. Nipple stop mechanism**

- Ratchet mechanism of our original lock ring is employed.
- Steady performance even for movable piping.
- Pressure variation is accommodated.

**2. Detachable hose**

- Hose is detachable for length adjustment when piping.
  - Detachable tool is available.
- △ Caution: Cannot be detached after pressurization.

**3. Correcting hose's twisted direction**

- It is possible to correct the twisted direction of a hose.
- △ Caution: Cannot be detached after pressurization.

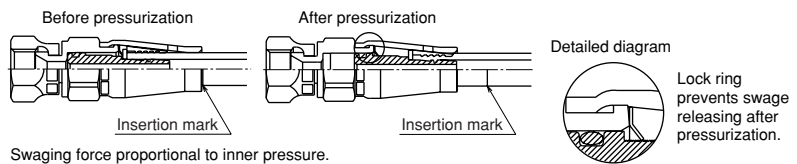
**Campucka assembly mechanism**

△Caution: Handle with care not to drop couplings as an inner nipple could be self locked by pushing-out action to inlet of coupling.

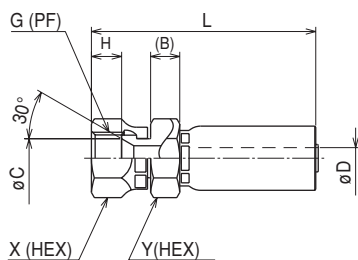
**[Swage]****SE**

Part No.	Size No.	G	B	C	Min. I.D. øD	H	L	X (HEX)	Y (HEX)	Wt. (g)	Pusher	Die
SSE-PF-02	02	1/8	4.0	7.0	1.8	7.0	42	14	14	25	PSE-02-001	SP3-02-001
SE-PF-04	04	1/4	8.0	9.0	3.9	8.0	64	19	19	80	PSE-04	SP3-04
SE-PF-06	06	3/8	9.5	12.5	6.8	9.5	71	22	22	110	PSE-06	SP3-06
SE-PF-08	08	1/2	9.0	15.5	10.0	12.5	80	27	27	170	PSE-08	SP3-08
SE-PF-12	12	3/4	10.5	21.5	16.0	13.0	87	36	36	280	PSE-12	SP3-12
SE-PF-16	16	1	11.0	27.5	20.9	15.0	105	41	41	400	PSE-16	SP3-16

- Material: steel
- Surface finishing: zinc electro-galvanized with color chromating (Ep-Fe/Zn 5/CM2)
- Adaptor: 010, 045, 090, 150, 020, 025, 064, 069, 030, D70, D74, D79

# N3130-3130-3000 Series

## N3130

### Features

- Flexible and tough
- JIS K 6375 certificated, SAE100R7 certificated.

Nonconductive hose with high electrical insulation is also available. Contact us for details.

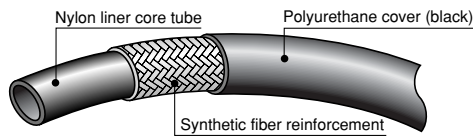

Part No.	Size No.	Size		Max. working press. (MPa)	Max. impact press. (MPa)	Min. destruction press. (MPa)	Min. bending radius (mm)	Weight (g/m)	Coupling	
		I.D. (in.)	I.D. (mm)							O.D. (mm)
* N3130-03	03	3/16	4.8	10.4	21.0	26.3	84.0	20	65	Swage
* N3130-04	04	1/4	6.4	12.7	19.5	24.4	77.0	40	105	
N3130-05	05	5/16	8.1	14.7	17.5	21.9	70.0	45	130	
* N3130-06	06	3/8	9.8	16.4	16.0	20.0	63.0	50	150	
* N3130-08	08	1/2	12.8	20.3	14.0	17.5	56.0	75	210	
* N3130-12	12	3/4	19.2	26.6	9.0	11.3	35.0	130	290	
* N3130-16	16	1	25.7	33.4	7.0	8.8	28.0	165	400	

- Appropriate fluid: mineral general operating oil
- Working temperature range: -40 to +100°C
- Length in a package: 100 m for sizes 03, 04, 05, 06, 08 and 50 m for sizes 12, 16

## 3130

### Features

- Excellent oil and chemical durability
- Reusable coupling can be used.

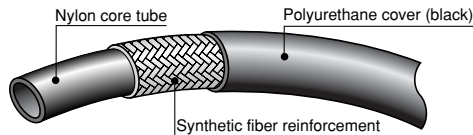

Part No.	Size No.	Size		Max. working press. (MPa)	Max. impact press. (MPa)	Min. destruction press. (MPa)	Min. bending radius (mm)	Weight (g/m)	Coupling	
		I.D. (in.)	I.D. (mm)							O.D. (mm)
3130-02	02	1/8	3.6	8.3	20.0	25.0	72.0	15	45	Swage Reusable Campucka can be used only for size 02.
* 3130-03	03	3/16	4.8	10.4	20.0	25.0	72.0	30	65	
* 3130-04	04	1/4	6.3	12.4	20.0	25.0	72.0	40	105	
3130-05	05	5/16	7.9	13.8	18.0	22.5	65.0	50	115	
* 3130-06	06	3/8	9.5	16.1	18.0	22.5	65.0	60	150	
* 3130-08	08	1/2	12.7	19.9	16.0	20.0	58.0	80	210	
* 3130-12	12	3/4	19.0	26.2	10.0	12.5	36.0	160	290	

- Appropriate fluid: mineral general operating oil
- Working temperature range: -40 to +100°C
- Length in a package: 100 m for sizes 03, 04, 05, 06, 08 and 50 m for sizes 12, 16

## 3000

### Features

- Excellent oil and chemical durability
- Reusable coupling can be used.

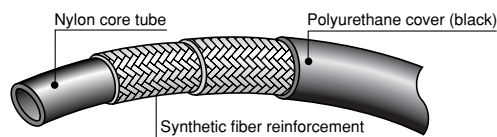

Part No.	Size No.	Size		Max. working press. (MPa)	Max. impact press. (MPa)	Min. destruction press. (MPa)	Min. bending radius (mm)	Weight (g/m)	Coupling	
		I.D. (in.)	I.D. (mm)							O.D. (mm)
* 3000-03	03	3/16	4.8	10.4	34.0	42.5	100.0	70	76	Swage Reusable
* 3000-04	04	1/4	6.3	12.5	30.0	37.5	90.0	75	98	
* 3000-06	06	3/8	9.5	16.0	24.0	30.0	70.0	120	140	
* 3000-08	08	1/2	12.7	19.8	20.0	25.0	60.0	160	199	
* 3000-12	12	3/4	19.0	26.2	13.0	16.3	38.0	250	276	
* 3000-16	16	1	25.4	33.0	10.0	12.5	30.0	300	366	

- Appropriate fluid: mineral general operating oil
- Working temperature range: -40 to +100°C
- Length in a package: 100 m for sizes 03, 04, 06, 08 and 50 m for sizes 12, 16

The \* mark above indicates that the outer wire braid type is available (made-to-order). Contact us for details.

### Nonconductive hose

When electrical insulation is particularly necessary, e.g. for the hydraulic hose of electrical work equipment, a nonconductive hose without pin pricking (no pin hole for gas venting) is useful to prevent the reduction of electrical insulation due to external water invasion.

Contact us if the leakage of electrical current should be controlled.

# 3700 Series (for low temperature environment)

3700

## Features

- High flexibility and steady performance under low temperature environment (-55°C).
- JIS K 6375 A certificated, SAE 100R7 certificated.

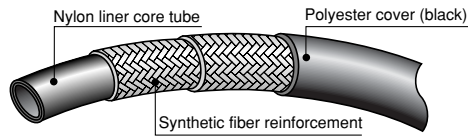

Part No.	Size No.	Size			Max. working press. (MPa)	Max. impact press. (MPa)	Min. destruction press. (MPa)	Min. bending radius (mm)	Weight (g/m)	Coupling
		I.D. (in.)	I.D. (mm)	O.D. (mm)						
* 3700-03	03	3/16	4.8	10.5	21.0	26.3	84.0	19	76	Swage
* 3700-04	04	1/4	6.3	12.8	19.5	24.4	77.0	32	101	
* 3700-06	06	3/8	9.5	16.3	16.0	20.0	63.0	51	141	
* 3700-08	08	1/2	12.7	20.2	14.0	17.5	56.0	76	196	

- Appropriate fluid: mineral general operating oil
- Working temperature range: -55 to +100°C
- Length in a package: 100m

The \* mark above indicates that the outer wire braid type is available (made-to-order). Contact us for details.

[Swage]

(For N3130, 3130, 3000) (For 3700)

SA

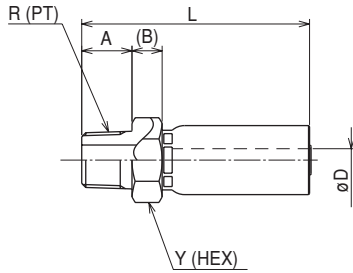

Part No.	Size No.	R	A	B	Min. I.D. øD	L	Y (HEX)	Wt. (g)	Pusher	Die
SSA-PT-02	02	1/8	10	6.5	1.8	38	14	15	PSA-02	SP3-02-001
SA-PT-03	03	1/4	13	8.5	2.8	57	19	50	PSA-04	SP3-03
SA-PT-04	04	1/4	14	8.5	3.9	61	19	60	PSA-04	SP3-04
SA-PT-05	05	3/8	15	9.0	5.6	62	22	80	PSA-06	SP3-05
SA-PT-06	06	3/8	15	9.0	6.8	67	22	90	PSA-06	SP3-06
SA-PT-08	08	1/2	18	10.0	10.0	76	27	140	PSA-08	SP3-08
SA-PT-12	12	3/4	20	10.0	16.0	82	36	220	PSA-12	SP3-12
SA-PT-16	16	1	23	10.0	20.9	100	41	340	PSA-16	SP3-16

- Material: steel
- Surface finishing: zinc electro-galvanized with color chromating (Ep-Fe/Zn 5/CM2)
- Adaptor: 030, 130

Stainless type

Part No.	Size No.	R	A	B	Min. I.D. øD	L	Y (HEX)	Wt. (g)	Pusher	Die	
										First	Second
SSA-PT-02-S	02	1/8	10	6.5	1.8	38	14	15	PSA-02	SP3-02-001	—
SA-PT-03-S	03	1/4	13	8.5	3.0	57	19	50	PSA-04	SP3-03-1-ST	SP3-03
SA-PT-04-S	04	1/4	13	8.5	3.9	60	19	60	PSA-04	SP3-04-1-ST	KM-04 SP3-04
SA-PT-06-S	06	3/8	15	9.0	6.8	67	22	90	PSA-06	SP3-06-1-ST	SP3-06
SA-PT-08-S	08	1/2	18	10.0	10.0	76	27	140	PSA-08	SP3-08-1-ST	SP3-08
SA-PT-12-S	12	3/4	20	10.0	16.0	82	36	220	PSA-12	SP3-12-1-ST	SP3-12
SA-PT-16-S	16	1	23	10.0	20.9	100	41	340	PSA-16	SP3-16-1-ST	SP3-16

- Material: stainless steel SUS304
- Adaptor: 030, 130
- \* Use KM-04 for N3130 and 3700, and SP3-04 for 3130 and 3000.

SO

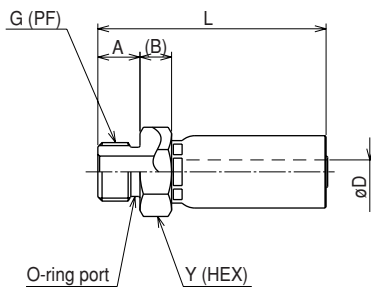

Part No.	Size No.	G	A	B	Min. I.D. øD	L	Y (HEX)	Wt. (g)	Pusher	Die
SO-PF-04	04	1/4	11	8.5	3.9	59	19	55	PSA-04	SP3-04
SO-PF-06	06	3/8	12	9.0	6.8	64	22	85	PSA-06	SP3-06
★ SO-PF-08	08	1/2	15	10.0	10.0	73	27	135	PSA-08	SP3-08

- Material: steel
- Surface finishing: zinc electro-galvanized with color chromating (Ep-Fe/Zn 5/CM2)
- O-ring: 04-JIS B2401-P11, 06-JIS B2401-P14, 08-JIS B2401-P18
- ☞ O-ring is not mounted inside.
- ★ Made-to-order

SC

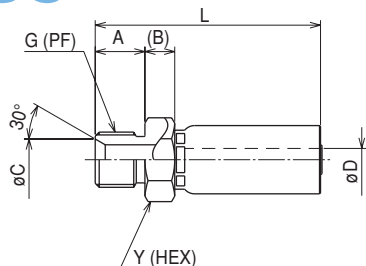

Part No.	Size No.	G	A	B	C	Min. I.D. øD	L	Y (HEX)	Wt. (g)	Pusher	Die
SC-PF-03	03	1/4	13	8.5	9.5	2.8	57	19	50	PSA-03	SP3-03
SC-PF-04	04	1/4	14	8.5	9.5	3.9	61	19	60	PSA-04	SP3-04
SC-PF-06	06	3/8	15	9.0	12.5	6.8	67	22	90	PSA-06	SP3-06
SC-PF-08	08	1/2	18	10.0	16.5	10.0	76	27	140	PSA-08	SP3-08
SC-PF-12	12	3/4	20	10.0	21.5	16.0	82	36	220	PSA-12	SP3-12
SC-PF-16	16	1	22	10.0	27.5	20.9	99	41	340	PSA-16	SP3-16

- Material: steel
- Surface finishing: zinc electro-galvanized with color chromating (Ep-Fe/Zn 5/CM2)
- Adaptor: 060

[Swage]

(For N3130, 3130, 3000) (For 3700)

SE

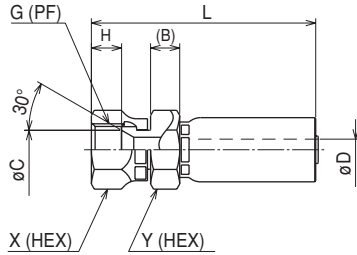

Part No.	Size No.	G	B	C	Min. I.D. øD	H	L	X (HEX)	Y (HEX)	Wt. (g)	Pusher	Die
SSE-PF-02	02	1/8	4.0	7.0	1.8	7.0	42	14	14	25	PSE-02-001	SP3-02-001
SE-PF-03	03	1/4	6.0	9.5	2.8	8.0	58	19	19	70	PSE-03	SP3-03
SE-PF-04	04	1/4	8.0	9.0	3.9	8.0	64	19	19	80	PSE-04	SP3-04
SE-PF-05	05	3/8	8.5	12.0	5.6	10.0	66	22	22	100	PSE-05	SP3-05
SE-PF-06	06	3/8	9.5	12.5	6.8	10.0	71	22	22	110	PSE-06	SP3-06
SE-PF-08	08	1/2	9.0	15.5	10.0	12.5	80	27	27	170	PSE-08	SP3-08
SE-PF-12	12	3/4	10.5	21.5	16.0	13.0	87	36	36	280	PSE-12	SP3-12
SE-PF-16	16	1	11.0	27.5	20.9	15.0	105	41	41	400	PSE-16	SP3-16

- Material: steel
- Surface finishing: zinc electro-galvanized with color chromating (Ep-Fe/Zn 5/CM2)
- Adaptor: 010, 045, 090, 150, 020, 025, 064, 069, 030, D70, D74, D79

## Stainless type

Part No.	Size No.	G	B	C	Min. I.D. øD	H	L	X (HEX)	Y (HEX)	Wt. (g)	Pusher	Die	
												First	Second
SSE-PF-02-S	02	1/8	4.0	7.0	1.8	7.0	42	14	14	25	PSE-02-001	SP3-02-001	—
SE-PF-03-S	03	1/4	6.0	9.0	3.0	8.0	58	19	19	70	PSE-03	SP3-03-1-ST	SP3-03
SE-PF-04-S	04	1/4	8.5	9.5	3.9	8.0	63	19	19	80	PSE-04	SP3-04-1-ST	KM-04 SP3-04
SE-PF-06-S	06	3/8	9.5	12.5	6.8	10.0	71	22	22	110	PSE-06	SP3-06-1-ST	SP3-06
SE-PF-08-S	08	1/2	9.0	16.0	10.0	12.0	80	27	27	170	PSE-08	SP3-08-1-ST	SP3-08
SE-PF-12-S	12	3/4	10.5	21.5	16.0	13.0	87	36	36	280	PSE-12	SP3-12-1-ST	SP3-12
SE-PF-16-S	16	1	11.0	27.5	20.9	15.0	105	41	41	400	PSE-16	SP3-16-1-ST	SP3-16

- Material: stainless steel SUS304
- Adaptor: 010, 045, 090, 150, 020, 025, 064, 069, 030, D70, D74, D79
- \* Use KM-04 for N3130 and 3700, and SP3-04 for 3130 and 3000.

SF

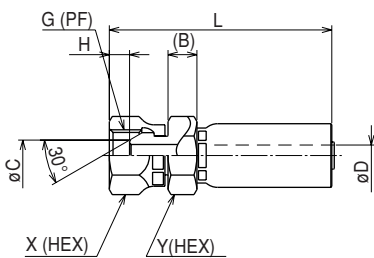

Part No.	Size No.	G	B	C	Min. I.D. øD	H	L	X (HEX)	Y (HEX)	Wt. (g)	Pusher	Die
SSF-PF-02	02	1/8	4.0	5.0	1.8	3.0	41	14	14	25	PSE-02-001	SP3-02-001
SF-PF-03	03	1/4	6.0	7.5	2.8	5.5	58	19	19	70	PSE-03	SP3-03
SF-PF-04	04	1/4	8.5	7.5	3.9	5.5	63	19	19	80	PSE-04	SP3-04
SF-PF-05	05	3/8	8.5	10.0	5.6	6.5	66	22	22	100	PSE-05	SP3-05
SF-PF-06	06	3/8	9.5	10.0	6.8	6.5	71	22	22	110	PSE-06	SP3-06
SF-PF-08	08	1/2	9.0	14.0	10.0	9.0	80	27	27	170	PSE-08	SP3-08
SF-PF-12	12	3/4	10.5	19.0	16.0	9.5	87	36	36	280	PSE-12	SP3-12
SF-PF-16	16	1	11.0	25.4	20.9	10.0	105	41	41	410	PSE-16	SP3-16

- Material: steel
- Surface finishing: zinc electro-galvanized with color chromating (Ep-Fe/Zn 5/CM2)
- Adaptor: 110, 145, 190, 130, C70, C74, C79

## Stainless type

Part No.	Size No.	G	B	C	Min. I.D. øD	H	L	X (HEX)	Y (HEX)	Wt. (g)	Pusher	Die	
												First	Second
SSF-PF-02-S	02	1/8	4.0	5.0	1.8	3.0	41	14	14	25	PSE-02-001	SP3-02-001	—
SF-PF-04-S	04	1/4	8.5	7.5	3.9	5.5	63	19	19	80	PSE-04	SP3-04-1-ST	KM-04 SP3-04
SF-PF-06-S	06	3/8	9.5	10.0	6.8	6.5	71	22	22	110	PSE-06	SP3-06-1-ST	SP3-06
SF-PF-08-S	08	1/2	9.0	13.2	10.0	9.0	80	27	27	170	PSE-08	SP3-08-1-ST	SP3-08
SF-PF-12-S	12	3/4	10.5	19.0	16.0	9.5	87	36	36	280	PSE-12	SP3-12-1-ST	SP3-12
SF-PF-16-S	16	1	11.0	25.4	20.9	10.0	105	41	41	400	PSE-16	SP3-16-1-ST	SP3-16

- Material: stainless steel SUS304
- Adaptor: 110, 145, 190, 130, C70, C74, C79
- \* Use KM-04 for N3130 and 3700, and SP3-04 for 3130 and 3000.



[Swage]

(For N3130, 3130, 3000) (For 3700)

# SLE

Made-to-order

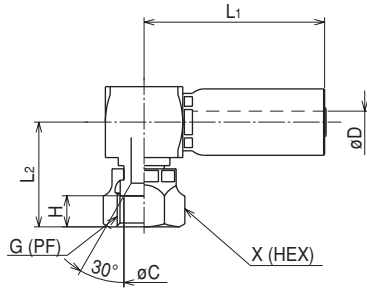

Part No.	Size No.	G	C	Min. I.D. øD	H	L <sub>1</sub>	L <sub>2</sub>	X (HEX)	Wt. (g)	Pusher	Die
★ SLE-PF-04	04	1/4	9.5	3.9	8.0	49	28	19	115	PSL-04	SP3-04
★ SLE-PF-06	06	3/8	12.5	6.8	9.5	55	33	22	116	PSL-06	SP3-06
★ SLE-PF-08	08	1/2	16.0	10.0	12.0	62	37	27	255	PSL-08	SP3-08

- Material: steel
- Surface finishing: zinc electro-galvanized with color chromating (Ep-Fe/Zn 5/CM2)
- Adaptor: 010, 045, 090, 150, 020, 025, 064, 069, 030, D70, D74, D79
- ★ Made-to-order

# SL

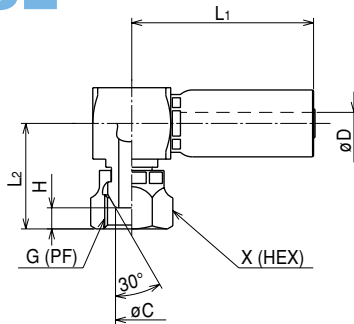

Part No.	Size No.	G	C	Min. I.D. øD	H	L <sub>1</sub>	L <sub>2</sub>	X (HEX)	Wt. (g)	Pusher	Die
SL-PF-04	04	1/4	7.5	3.9	5.5	54	28	19	115	PSL-04	SP3-04
SL-PF-06	06	3/8	10.0	6.8	6.5	55	33	22	165	PSL-06	SP3-06
SL-PF-08	08	1/2	13.2	10.0	9.0	62	37	27	255	PSL-08	SP3-08
★ SL-PF-12	12	3/4	19.0	16.0	9.5	71	43	36	550	PSL-12	SP3-12

- Material: steel
- Surface finishing: zinc electro-galvanized with color chromating (Ep-Fe/Zn 5/CM2)
- Adaptor: 110, 145, 190, 130, C70, C74, C79
- ★ Made-to-order

# AE45·SE45

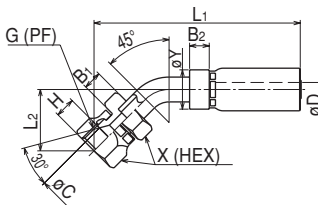
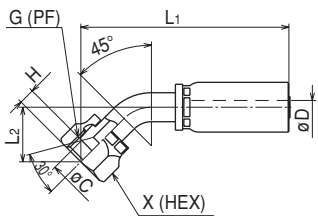

Part No.	Size No.	G	C	Min. I.D. øD	H	L <sub>1</sub>	L <sub>2</sub>	X (HEX)	Wt. (g)	Pusher	Die
AE45-G-04	04	1/4	9.0	3.2	8.0	71	18	19	70	PFB-01+PA-04	SP3-04
AE45-G-06	06	3/8	12.0	5.6	9.5	87	25	22	105	PFB-01+PA-06	SP3-06
AE45-G-08	08	1/2	15.5	8.7	12.5	102	29	27	170	PFB-01+PA-08	SP3-08

- Material: steel
- Surface finishing: zinc electro-galvanized with color chromating (Ep-Fe/Zn 5/CM2)
- Adaptor: 010, 045, 090, 150, 020, 025, 064, 069, 030, D70, D74, D79

Part No.	Size No.	G	B <sub>1</sub>	B <sub>2</sub>	C	Min. I.D. øD	H	L <sub>1</sub>	L <sub>2</sub>	X (HEX)	øY	Wt. (g)	Pusher	Die
★ SE45-PF-12	12	3/4	10.5	12.5	21.0	16.0	13.5	129	40	36	30	380	PFB-02+PHB-12	SP3-12
★ SE45-PF-16	16	1	12.5	12.5	28.0	20.9	16.5	154	47	41	36	590	PFB-02+PHB-16	SP3-16

- Material: steel
- Surface finishing: zinc electro-galvanized with color chromating (Ep-Fe/Zn 5/CM2)
- Adaptor: 010, 045, 090, 150, 020, 025, 064, 069, 030, D70, D74, D79
- ★ Made-to-order

[Swage]

(For N3130, 3130, 3000) (For 3700)

## AE90·SE90

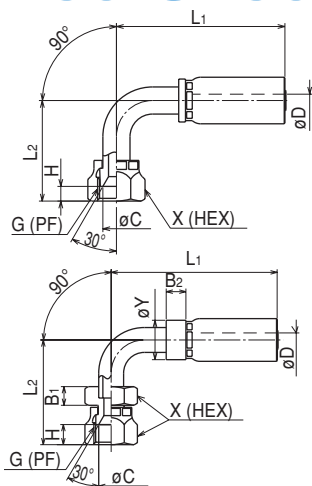

Part No.	Size No.	G	C	Min. I.D. øD	H	L <sub>1</sub>	L <sub>2</sub>	X (HEX)	Wt. (g)	Pusher	Die
AE90-G-04	04	1/4	9.0	3.2	8.0	59	33	19	75	PFB-01+PA-04	SP3-04
AE90-G-06	06	3/8	12.0	5.6	9.5	74	45	22	115	PFB-01+PA-06	SP3-06
AE90-G-08	08	1/2	15.5	8.7	12.5	83	52	27	180	PFB-01+PA-08	SP3-08

- Material: steel
- Surface finishing: zinc electro-galvanized with color chromating (Ep-Fe/Zn 5/CM2)
- Adaptor: 010, 045, 090, 150, 020, 025, 064, 069, 030, D70, D74, D79

Part No.	Size No.	G	B <sub>1</sub>	B <sub>2</sub>	C	Min. I.D. øD	H	L <sub>1</sub>	L <sub>2</sub>	X (HEX)	øY	Wt. (g)	Pusher	Die
SE90-PF-12	12	3/4	10.5	12.5	21.0	16.0	13.5	108	77	36	30	405	PFB-02+PHB-12	SP3-12
SE90-PF-16	16	1	12.5	12.5	28.0	20.9	16.5	127	87	41	36	645	PFB-02+PHB-16	SP3-16

- Material: steel
- Surface finishing: zinc electro-galvanized with color chromating (Ep-Fe/Zn 5/CM2)
- Adaptor: 010, 045, 090, 150, 020, 025, 064, 069, 030, D70, D74, D79

## AF45·SF45

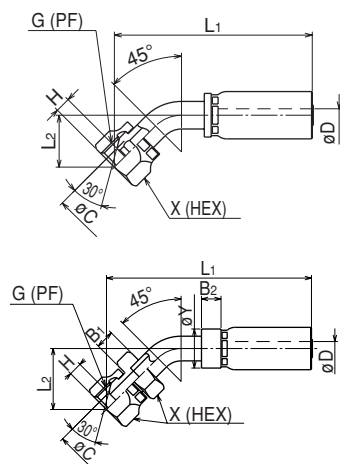

Part No.	Size No.	G	C	Min. I.D. øD	H	L <sub>1</sub>	L <sub>2</sub>	X (HEX)	Wt. (g)	Pusher	Die
AF45-G-04	04	1/4	7.0	3.2	5.5	73	19	19	70	PFB-01+PA-04	SP3-04
AF45-G-06	06	3/8	10.0	5.6	6.5	85	23	22	110	PFB-01+PA-06	SP3-06
AF45-G-08	08	1/2	14.0	8.7	9.0	103	29	27	155	PFB-01+PA-08	SP3-08

- Material: steel
- Surface finishing: zinc electro-galvanized with color chromating (Ep-Fe/Zn 5/CM2)
- Adaptor: 110, 145, 190, 130, C70, C74, C79

Part No.	Size No.	G	B <sub>1</sub>	B <sub>2</sub>	C	Min. I.D. øD	H	L <sub>1</sub>	L <sub>2</sub>	X (HEX)	øY	Wt. (g)	Pusher	Die
SF45-PF-12	12	3/4	10.5	12.5	19.0	16.0	9.5	129	40	36	30	381	PFB-02+PHB-12	SP3-12
SF45-PF-16	16	1	11.0	12.5	25.4	20.9	10.0	151	60	41	36	601	PFB-02+PHB-16	SP3-16

- Material: steel
- Surface finishing: zinc electro-galvanized with color chromating (Ep-Fe/Zn 5/CM2)
- Adaptor: 110, 145, 190, 130, C70, C74, C79
- ★ Made-to-order

## AF90·SF90

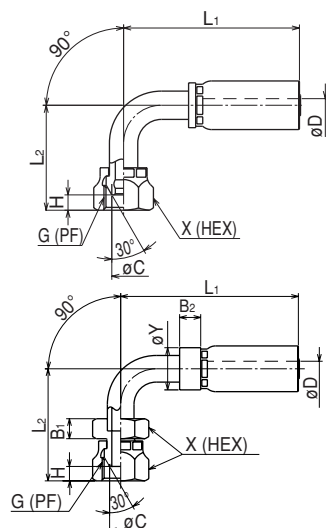

Part No.	Size No.	G	C	Min. I.D. øD	H	L <sub>1</sub>	L <sub>2</sub>	X (HEX)	Wt. (g)	Pusher	Die
AF90-G-04	04	1/4	7.0	3.2	5.5	61	33	19	75	PFB-01+PA-04	SP3-04
AF90-G-06	06	3/8	10.0	5.6	6.5	74	45	22	115	PFB-01+PA-06	SP3-06
AF90-G-08	08	1/2	14.0	8.7	9.0	83	52	27	165	PFB-01+PA-08	SP3-08

- Material: steel
- Surface finishing: zinc electro-galvanized with color chromating (Ep-Fe/Zn 5/CM2)
- Adaptor: 110, 145, 190, 130, C70, C74, C79

Part No.	Size No.	G	B <sub>1</sub>	B <sub>2</sub>	C	Min. I.D. øD	H	L <sub>1</sub>	L <sub>2</sub>	X (HEX)	øY	Wt. (g)	Pusher	Die
SF90-PF-12	12	3/4	10.5	12.5	19.0	16.0	9.5	108	77	36	30	405	PFB-02+PHB-12	SP3-12
SF90-PF-16	16	1	11.0	12.5	25.4	20.9	10.0	127	86	41	36	645	PFB-02+PHB-16	SP3-16

- Material: steel
- Surface finishing: zinc electro-galvanized with color chromating (Ep-Fe/Zn 5/CM2)
- Adaptor: 110, 145, 190, 130, C70, C74, C79
- ★ Made-to-order

[Swage]

(For N3130, 3130, 3000) (For 3700)

# SK

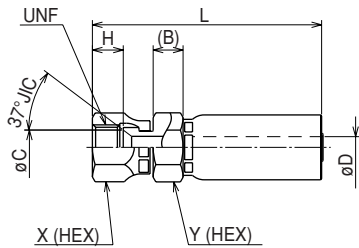

Part No.	Size No.	UNF	B	C	Min. I.D. øD	H	L	X (HEX)	Y (HEX)	Wt. (g)	Pusher	Die
SK-7/16-03	03	7/16	6.5	7.5	2.8	10.0	58	15.9	14.3	50	PSK-7/16-04	SP3-03
SK-7/16-04	04	7/16	6.5	7.5	3.9	10.0	61	15.9	15.9	60	PSK-7/16-04	SP3-04
★ SK-1/2-04	04	1/2	9.5	9.0	3.9	9.5	65	19.0	15.9	60	PSK-1/2-04	SP3-04
★ SK-9/16-04	04	9/16	7.0	11.0	3.9	10.0	65	19.0	15.9	65	PSK-9/16-04	SP3-04
SK-9/16-06	06	9/16	9.5	11.0	6.8	10.0	72	19.0	19.0	90	PSK-9/16-06	SP3-06
★ SK-3/4-06	06	3/4	8.5	14.5	6.8	12.0	72	24.0	19.0	95	PSK-3/4-06	SP3-06
SK-3/4-08	08	3/4	9.0	14.5	10.0	12.0	77	24.0	22.0	125	PSK-3/4-08	SP3-08
★ SK-7/8-08	08	7/8	9.0	17.3	10.0	13.0	81	27.0	22.0	145	PSE-08	SP3-08

- Material: steel
- Surface finishing: zinc electro-galvanized with color chromating (Ep-Fe/Zn 5/CM2)
- ★ Made-to-order

# AK45

Made-to-order

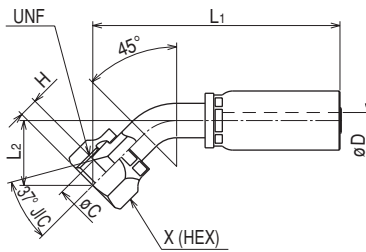

Part No.	Size No.	UNF	C	Min. I.D. øD	H	L <sub>1</sub>	L <sub>2</sub>	X (HEX)	Wt. (g)	Pusher	Die
★ AK45-7/16-03	03	7/16	7.5	2.6	9.0	69	18	19	57	PFB-01+PA-04	SP3-03
★ AK45-7/16-04-C	04	7/16	7.5	3.2	9.0	72	18	19	64	PFB-01+PA-04	SP3-04
★ AK45-9/16-06-C	06	9/16	11.0	5.6	10.0	89	24	22	110	PFB-01+PA-06	SP3-06
★ AK45-3/4-08-C	08	3/4	14.5	8.7	11.5	100	27	27	161	PFB-01+PA-08	SP3-08

- Material: steel
- Surface finishing: zinc electro-galvanized with color chromating (Ep-Fe/Zn 5/CM2)
- ★ Made-to-order

# AK90

Made-to-order

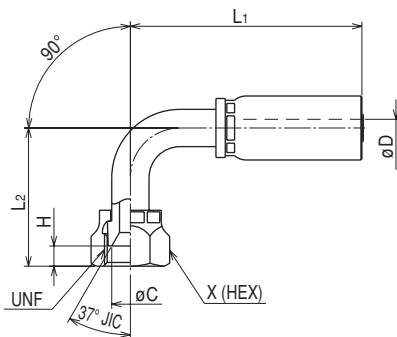

Part No.	Size No.	UNF	C	Min. I.D. øD	H	L <sub>1</sub>	L <sub>2</sub>	X (HEX)	Wt. (g)	Pusher	Die
★ AK90-7/16-03	03	7/16	7.5	2.6	9.0	58	32	19	62	PFB-01+PA-04	SP3-03
★ AK90-7/16-04-C	04	7/16	7.5	3.2	9.0	61	32	19	69	PFB-01+PA-04	SP3-04
★ AK90-9/16-06-C	06	9/16	11.0	5.6	10.0	74	43	22	117	PFB-01+PA-06	SP3-06
★ AK90-3/4-08-C	08	3/4	14.5	8.7	11.5	83	47	27	171	PFB-01+PA-08	SP3-08

- Material: steel
- Surface finishing: zinc electro-galvanized with color chromating (Ep-Fe/Zn 5/CM2)
- ★ Made-to-order

[Campucka] Hydraulic push-one coupling

(For N3130, 3130, 3000) (For 3700)

CA

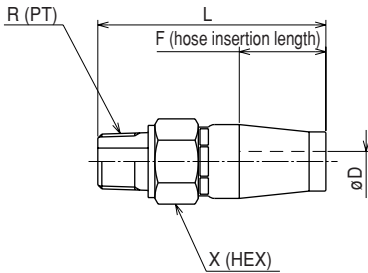

Part No.	Size No.	R	Min. I.D. øD	F	L	X	Weight (g)
CA-R-02L	02	1/8	1.5	22.5	56	14	36

△ Caution: Handle with care not to drop couplings as an inner nipple could be self locked by pushing-out action to inlet of coupling.

- Material: steel
- Surface finishing: zinc electro-galvanized with color chromating (Ep-Fe/Zn 5/CM2)
- Working temperature range: 20.0MPa
- Working temperature range: -20 to +100°C
- Adaptor: 030, 130

CE

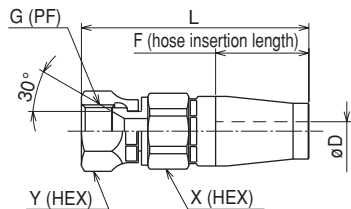

Part No.	Size No.	G	Min. I.D. øD	F	L	X	Y	Weight (g)
CE-G-02L	02	1/8	1.5	22.5	62	14	14	44

△ Caution: Handle with care not to drop couplings as an inner nipple could be self locked by pushing-out action to inlet of coupling.

- Material: steel
- Surface finishing: zinc electro-galvanized with color chromating (Ep-Fe/Zn 5/CM2)
- Working temperature range: 20.0MPa
- Working temperature range: -20 to +100°C
- Adaptor: 010, 045, 090, 150, 030

CF

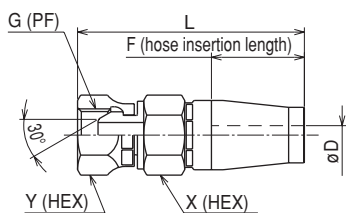

Part No.	Size No.	G	Min. I.D. øD	F	L	X	Y	Weight (g)
CF-G-02L	02	1/8	1.5	22.5	62	14	14	45

△ Caution: Handle with care not to drop couplings as an inner nipple could be self locked by pushing-out action to inlet of coupling.

- Material: steel
- Surface finishing: zinc electro-galvanized with color chromating (Ep-Fe/Zn 5/CM2)
- Working temperature range: 20.0MPa
- Working temperature range: -20 to +100°C
- Suitable adaptor: 110, 145, 190, 130

Features of Campucka and assembly mechanism

Assembling method P.73

1. Push-one connection

- Reduction of operation time (half that of our conventional product)
- Specialized swaging tool is not necessary. (Easy handling)
- Best for on-site length adjustment.
- Convenient for emergency repair.

4. Nipple stop mechanism

- Ratchet mechanism of our original lock ring is employed.
- Steady performance even for movable piping.
- Pressure variation is accommodated.

2. Detachable hose

- Hose is detachable for length adjustment when piping.
- Detachable tool is available.
- △ Caution: Cannot be detached after pressurization.

3. Correcting hose's twisted direction

- It is possible to correct the twisted direction of a hose.
- △ Caution: Cannot be detached after pressurization.

Campucka assembly mechanism

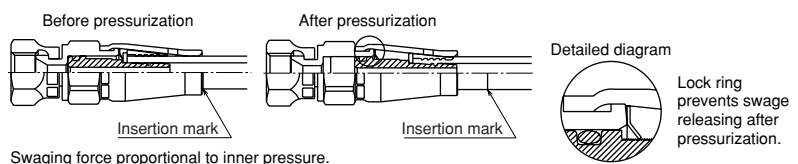

△ Caution: Handle with care not to drop couplings as an inner nipple could be self locked by pushing-out action to inlet of coupling.

[Reusable]

(For 3130, 3000)

**A**

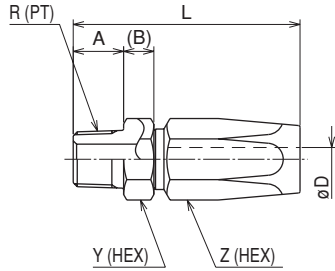

Part No.	Size No.	R	A	B	Min. I.D. øD	L	Y (HEX)	Z (HEX)	Weight (g)
A-PT-02	02	1/8	10	6.5	2.8	42	12	12	25
A-PT-03	03	1/4	14	7.0	3.4	51	17	14	45
A-PT-04	04	1/4	14	7.0	5.0	57	17	17	60
A-PT-05	05	3/8	15	9.0	6.0	65	21	19	100
A-PT-06	06	3/8	15	9.0	7.0	68	21	21	120
A-PT-08	08	1/2	18	10.0	9.6	79	26	26	210
A-PT-12	12	3/4	20	12.0	16.5	85	35	35	370
★ A-PT-16	16	1	23	13.0	21.5	92	41	41	500

- Material: steel
- Surface finishing: zinc electro-galvanized with color chromating (Ep-Fe/Zn 5/CM1)
- Adaptor: 030, 130
- ★ Made-to-order

**Stainless type**

Part No.	Size No.	R	A	B	Min. I.D. øD	L	Y (HEX)	Z (HEX)	Weight (g)
A-PT-02-S	02	1/8	10	6.5	2.8	42	12	12	25
A-PT-04-S	04	1/4	14	7.0	5.0	57	17	17	60
A-PT-06-S	06	3/8	15	9.0	7.0	68	21	21	120
★ A-PT-08-S	08	1/2	18	10.0	9.6	79	26	26	210
★ A-PT-12-S	12	3/4	20	12.0	16.5	85	35	35	370

- Material: stainless steel SUS304
- Adaptor: 030, 130
- ★ Made-to-order

**E**

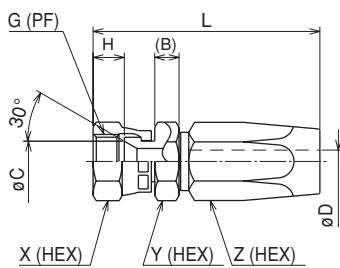

Part No.	Size No.	G	B	C	Min. I.D. øD	H	L	X (HEX)	Y (HEX)	Z (HEX)	Weight (g)
E-PF-02	02	1/8	6.5	7.0	2.8	7.0	48	14	12	12	35
E-PF-03	03	1/4	6.5	9.5	3.4	8.0	54	17	17	14	60
E-PF-04	04	1/4	6.5	9.5	5.0	8.5	59	17	17	17	70
E-PF-05	05	3/8	6.5	12.5	6.0	9.5	66	21	21	19	110
E-PF-06	06	3/8	7.5	12.5	7.0	9.5	70	21	21	21	130
E-PF-08	08	1/2	7.5	16.0	9.6	12.5	82	26	26	26	220
E-PF-12	12	3/4	9.5	21.5	16.5	13.0	86	35	35	35	400
E-PF-16	16	1	9.5	27.5	21.5	16.5	92	41	41	41	530

- Material: steel
- Surface finishing: zinc electro-galvanized with color chromating (Ep-Fe/Zn 5/CM1)
- Adaptor: 010, 045, 090, 150, 020, 025, 064, 069, 030, D70, D74, D79

**Stainless type**

Part No.	Size No.	G	B	C	Min. I.D. øD	H	L	X (HEX)	Y (HEX)	Z (HEX)	Weight (g)
E-PF-02-S	02	1/8	6.5	7.0	2.8	7.0	48	14	12	12	35
E-PF-04-S	04	1/4	6.5	9.5	5.0	8.5	59	17	17	17	70
E-PF-06-S	06	3/8	7.5	12.5	7.0	9.5	70	21	21	21	130
★ E-PF-08-S	08	1/2	7.5	16.0	9.6	12.5	82	26	26	26	220
★ E-PF-12-S	12	3/4	9.5	21.5	16.5	13.0	86	35	35	35	400

- Material: stainless steel SUS304
- Adaptor: 010, 045, 090, 150, 020, 025, 064, 069, 030, D70, D74, D79
- ★ Made-to-order

[Reusable]

(For 3130, 3000)

F

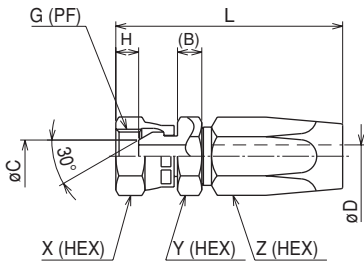

Part No.	Size No.	G	B	C	Min. I.D. øD	H	L	X (HEX)	Y (HEX)	Z (HEX)	Weight (g)
F-PF-02	02	1/8	6.5	5.0	2.8	3.0	48	14	12	12	35
F-PF-03	03	1/4	6.5	7.0	3.4	6.0	54	17	17	14	60
F-PF-04	04	1/4	6.5	7.0	5.0	6.0	59	17	17	17	70
F-PF-05	05	3/8	6.5	10.0	6.0	7.0	66	21	21	19	110
F-PF-06	06	3/8	7.5	10.0	7.0	7.0	70	21	21	21	130
F-PF-08	08	1/2	7.5	14.0	9.6	8.5	82	26	26	26	220
F-PF-12	12	3/4	9.5	19.0	16.5	9.0	86	35	35	35	410
★ F-PF-16	16	1	9.5	25.0	21.5	10.5	92	41	41	41	570

■ Material: steel

■ Surface finishing: zinc electro-galvanized with color chromating (Ep-Fe/Zn 5/CM1)

☞ On nipple only, zinc galvanization with color chromating

■ Adaptor: 110, 145, 190, 130, C70, C74, C79

★ Made-to-order

C

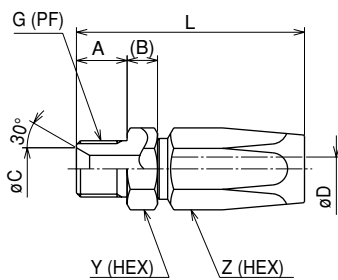

Part No.	Size No.	G	A	B	C	Min. I.D. øD	L	Y (HEX)	Z (HEX)	Weight (g)
C-PF-02	02	1/8	10	6.5	7.0	2.8	42	12	12	25
★ C-PF-03	03	1/4	14	7.0	9.5	3.4	51	17	14	45
C-PF-04	04	1/4	14	7.0	9.5	5.0	57	17	17	60
C-PF-06	06	3/8	15	9.0	12.5	7.0	68	21	21	120
C-PF-08	08	1/2	18	10.0	16.5	9.6	79	26	26	210
C-PF-12	12	3/4	20	12.0	22.0	16.5	85	35	35	500

■ Material: steel

■ Surface finishing: zinc electro-galvanized with color chromating (Ep-Fe/Zn 5/CM1)

■ Adaptor: 060

★ Made-to-order

# N3000 Series

## N3000

### Features

- Flexible and tough

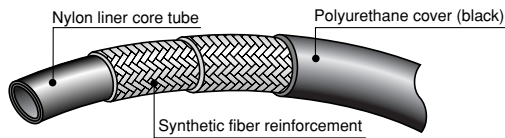

Part No.	Size No.	I.D.		O.D. (mm)	Max. working press. (MPa)	Max. impact press. (MPa)	Min. destruction press. (MPa)	Min. bending radius (mm)	Weight (g/m)	Coupling
		(in.)	(mm)							
N3000-04	04	1/4	6.3	13.3	28.0	37.3	112.0	50	120	Swage
* N3000-06	06	3/8	9.5	17.5	21.0	28.0	84.0	65	190	
* N3000-08	08	1/2	12.7	21.3	21.0	28.0	84.0	80	280	
N3000-10	10	5/8	15.9	25.5	17.5	23.3	70.0	120	355	

- Appropriate fluid: mineral general operating oil
- Working temperature range: -40 to +100°C
- Length in a package: 100 m for sizes 04, 06, 08, and 50 m for size 10

The \* mark above indicates that the outer wire braid type is available (made-to-order). Contact us for details.

# HT (High Temperature) Series

## HT (High Temperature)

### Features

- High temperature (120°C) oil can be used.

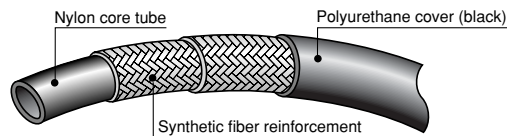

Part No.	Size No.	I.D.		O.D. (mm)	Max. working press. (MPa)	Max. impact press. (MPa)	Min. destruction press. (MPa)	Min. bending radius (mm)	Weight (g/m)	Coupling
		(in.)	(mm)							
HT-04	04	1/4	6.3	13.3	28.0	37.3	112.0	40	125	Swage
HT-06	06	3/8	9.5	17.5	21.0	28.0	84.0	60	180	
HT-08	08	1/2	12.7	21.3	21.0	28.0	84.0	80	255	
HT-10	10	5/8	15.9	25.5	17.5	23.3	70.0	120	335	

- Appropriate fluid: mineral general operating oil
- Working temperature range: -40 to +120°C
- Length in a package: 100 m for sizes 04, 06, 08, and 50 m for size 10

**[Swage]**

△ Caution: The size 04 coupling for N3130 can also be used, but the swage die must be used for N3000 and HT.

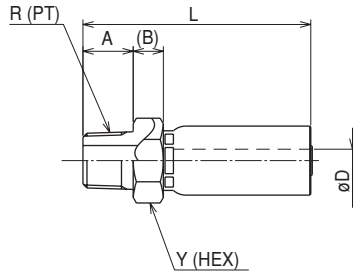
**(For N3000) (For HT)****SA**

Part No.	Size No.	R	A	B	Min. I.D. øD	L	Y (HEX)	Wt. (g)	Pusher	Die
SA-PT-04	04	1/4	14	8.5	3.9	61	19	60	PSA-04	SPN-04
SA-PT-06-N30	06	3/8	15	9.0	6.8	67	22	90	PSA-06	SPN-06
SA-PT-08-N30	08	1/2	18	10.0	10.0	76	27	140	PSA-08	SPN-08
SA-PT-10-N30	10	3/4	20	10.0	13.0	80	32	180	PSA-10	SPN-10

- Material: steel
- Surface finishing: zinc electro-galvanized with color chromating (Ep-Fe/Zn 5/CM2)
- Adaptor: 030, 130

**Stainless type**

Part No.	Size No.	R	A	B	Min. I.D. øD	L	Y (HEX)	Wt. (g)	Pusher	Die	
										First	Second
SA-PT-04-S	04	1/4	14	8.5	3.9	61	19	60	PSA-04	SPH-04-1-ST	SPN-04
SA-PT-06-N30-S	06	3/8	15	9.0	6.8	67	22	90	PSA-06	SPH-06-1-ST	SPN-06
SA-PT-08-N30-S	08	1/2	18	10.0	10.0	76	27	140	PSA-08	SPH-08-1-ST	SPN-08

- Material: stainless steel SUS304
- Adaptor: 030, 130

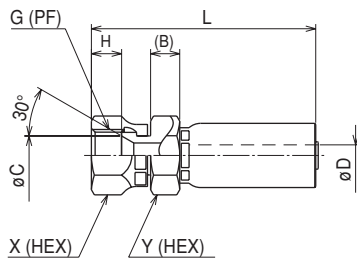
**SE**

Part No.	Size No.	G	B	C	Min. I.D. øD	H	L	X (HEX)	Y (HEX)	Wt. (g)	Pusher	Die
SE-PF-04	04	1/4	8.0	9.0	3.9	8.0	64	19	19	80	PSE-04	SPN-04
SE-PF-06-N30	06	3/8	9.5	12.5	6.8	9.5	71	22	22	110	PSE-06	SPN-06
SE-PF-08-N30	08	1/2	9.0	15.5	10.0	12.5	80	27	27	170	PSE-08	SPN-08
SE-PF-10-N30	10	3/4	10.5	21.0	13.1	13.0	84	32	32	220	PSE-10	SPN-10

- Material: steel
- Surface finishing: zinc electro-galvanized with color chromating (Ep-Fe/Zn 5/CM2)
- Adaptor: 010, 045, 090, 150, 020, 025, 064, 069, 030, D70, D74, D79

**Stainless type**

Part No.	Size No.	G	B	C	Min. I.D. øD	H	L	X (HEX)	Y (HEX)	Wt. (g)	Pusher	Die	
												First	Second
SE-PF-04-S	04	1/4	8.0	9.0	3.9	8.0	64	19	19	80	PSE-04	SPH-04-1-ST	SPN-04
SE-PF-06-N30-S	06	3/8	9.5	12.5	6.8	9.5	71	22	22	110	PSE-06	SPH-06-1-ST	SPN-06
SE-PF-08-N30-S	08	1/2	9.0	15.5	10.0	12.5	80	27	27	170	PSE-08	SPH-08-1-ST	SPN-08

- Material: stainless steel SUS304
- Adaptor: 010, 045, 090, 150, 020, 025, 064, 069, 030, D70, D74, D79

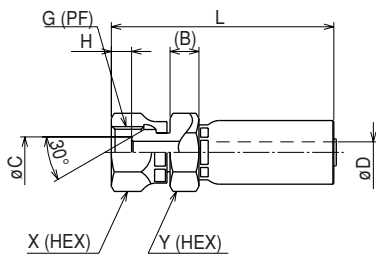
**SF**

Part No.	Size No.	G	B	C	Min. I.D. øD	H	L	X (HEX)	Y (HEX)	Wt. (g)	Pusher	Die
SF-PF-04	04	1/4	8.5	7.5	3.9	5.5	63	19	19	80	PSE-04	SPN-04
SF-PF-06-N30	06	3/8	9.5	10.0	6.8	6.5	71	22	22	110	PSE-06	SPN-06
SF-PF-08-N30	08	1/2	9.0	14.0	10.0	9.0	80	27	27	170	PSE-08	SPN-08
SF-PF-10-N30	10	3/4	10.5	19.0	13.1	9.5	84	32	32	220	PSE-10	SPN-10

- Material: steel
- Surface finishing: zinc electro-galvanized with color chromating (Ep-Fe/Zn 5/CM2)
- Adaptor: 110, 145, 190, 130, C70, C74, C79



**[Swage]**

△ Caution: The size 04 coupling for N3130 can also be used, but the swage die must be used for N3000 and HT.

**(For N3000) (For HT)**

**SO**

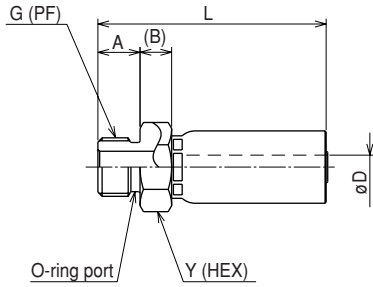

Part No.	Size No.	G	A	B	Min. I.D. $\phi D$	L	Y (HEX)	Wt. (g)	Pusher	Die
SO-PF-04	04	1/4	11	8.5	3.9	59	19	55	PSA-04	SPN-04
SO-PF-06-N30	06	3/8	12	9.0	6.8	64	22	85	PSA-06	SPN-06
SO-PF-08-N30	08	1/2	15	10.0	10.0	73	27	135	PSA-08	SPN-08

- Material: steel
- Surface finishing: zinc electro-galvanized with color chromating (Ep-Fe/Zn 5/CM2)
- O-ring: 04-JIS B2401-P11, 06-JIS B2401-P14, 08-JIS B2401-P18
- ☞ O-ring is not mounted inside.

**SC**

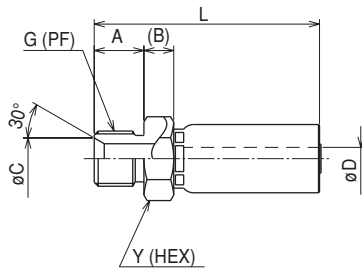

Part No.	Size No.	G	A	B	C	Min. I.D. $\phi D$	L	Y (HEX)	Wt. (g)	Pusher	Die
SC-PF-04	04	1/4	14	8.5	9.5	3.9	61	19	60	PSA-04	SPN-04
SC-PF-06-N30	06	3/8	15	9.0	12.5	6.8	67	22	90	PSA-06	SPN-06
★ SC-PF-08-N30	08	1/2	18	10.0	16.5	10.0	76	27	140	PSA-08	SPN-08
★ SC-PF-10-N30	10	5/8	20	10.0	22.0	13.0	80	32	180	PSA-10	SPN-10

- Material: steel
- Surface finishing: zinc electro-galvanized with color chromating (Ep-Fe/Zn 5/CM2)
- Adaptor: 060
- ★ Made-to-order

**SL**

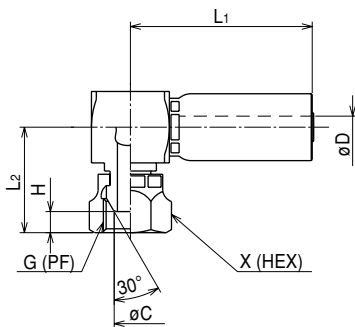

Part No.	Size No.	G	C	Min. I.D. $\phi D$	H	L <sub>1</sub>	L <sub>2</sub>	X (HEX)	Wt. (g)	Pusher	Die
SL-PF-04	04	1/4	7.5	3.9	5.5	54	28	19	115	PSL-04	SPN-04
SL-PF-06-N30	06	3/8	10.0	6.8	6.5	55	33	22	160	PSL-06	SPN-06
SL-PF-08-N30	08	1/2	13.2	10.0	9.0	62	37	27	255	PSL-08	SPN-08
SL-PF-10-N30	10	3/4	19.0	13.1	9.5	69	42	32	490	PSL-12	SPN-10

- Material: steel
- Surface finishing: zinc electro-galvanized with color chromating (Ep-Fe/Zn 5/CM2)
- Adaptor: 110, 145, 190, 130, C70, C74, C79

**[Swage]**

△ Caution: The size 04 coupling for N3130 can also be used, but the swage die must be used for N3000 and HT.

**(For N3000) (For HT)**

## AE90·SE90

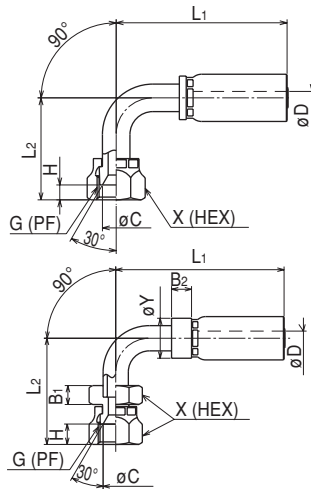

Part No.	Size No.	G	C	Min. I.D. øD	H	L <sub>1</sub>	L <sub>2</sub>	X (HEX)	Wt. (g)	Pusher	Die
AE90-G-04	04	1/4	9.0	3.2	8.0	59	33	19	75	PFB-01+PHB-04	SPN-04
AE90-G-06-N30	06	3/8	12.0	5.6	9.5	73	45	22	122	PFB-01+PHB-06	SPN-06
AE90-G-08-N30	08	1/2	15.5	8.7	12.5	83	52	27	189	PFB-01+PHB-08	SPN-08

■ Material: steel

■ Surface finishing: zinc electro-galvanized with color chromating (Ep-Fe/Zn 5/CM2)

■ Adaptor: 010, 045, 090, 150, 020, 025, 064, 069, 030, D70, D74, D79

Part No.	Size No.	G	C	Min. I.D. øD	H	L <sub>1</sub>	L <sub>2</sub>	X (HEX)	Wt. (g)	Pusher	Die
★ SE90-PF-10-N30	10	3/4	21.0	13.1	13.0	105	76	32	354	PFB-02+PHB-12	SPN-10

■ Material: steel

■ Surface finishing: zinc electro-galvanized with color chromating (Ep-Fe/Zn 5/CM2)

■ Adaptor: 010, 045, 090, 150, 020, 025, 064, 069, 030, D70, D74, D79

★ Made-to-order

## AF45·SF45

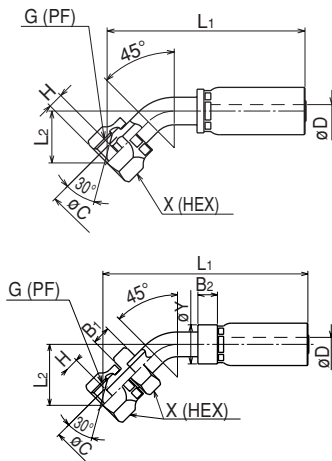

Part No.	Size No.	G	C	Min. I.D. øD	H	L <sub>1</sub>	L <sub>2</sub>	X (HEX)	Wt. (g)	Pusher	Die
AF45-G-04	04	1/4	7.0	3.2	5.5	73	19	19	70	PFB-01+PAF-04	SPN-04
AF45-G-06-N30	06	3/8	10.0	5.6	6.5	85	23	22	115	PFB-01+PHB-06	SPN-06
AF45-G-08-N30	08	1/2	14.0	8.7	9.0	103	29	27	185	PFB-01+PHB-08	SPN-08

■ Material: steel

■ Surface finishing: zinc electro-galvanized with color chromating (Ep-Fe/Zn 5/CM2)

■ Adaptor: 110, 145, 190, 130, C70, C74, C79

Part No.	Size No.	G	C	Min. I.D. øD	H	L <sub>1</sub>	L <sub>2</sub>	X (HEX)	Wt. (g)	Pusher	Die
★ SF45-PF-10-N30	10	3/4	19.0	13.1	9.5	126	40	32	335	PFB-02+PHB-12	SPN-10

■ Material: steel

■ Surface finishing: zinc electro-galvanized with color chromating (Ep-Fe/Zn 5/CM2)

■ Adaptor: 110, 145, 190, 130, C70, C74, C79

★ Made-to-order

## AF90·SF90

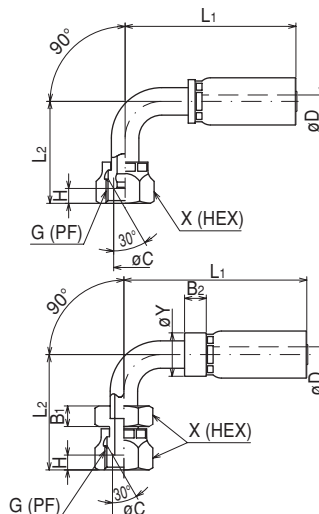

Part No.	Size No.	G	C	Min. I.D. øD	H	L <sub>1</sub>	L <sub>2</sub>	X (HEX)	Wt. (g)	Pusher	Die
AF90-G-04	04	1/4	7.0	3.2	5.5	61	33	19	75	PFB-01+PAF-04	SPN-04
AF90-G-06-N30	06	3/8	10.0	5.6	6.5	74	45	22	125	PFB-01+PHB-06	SPN-06
AF90-G-08-N30	08	1/2	14.0	8.7	9.0	83	52	27	190	PFB-01+PHB-08	SPN-08

■ Material: steel

■ Surface finishing: zinc electro-galvanized with color chromating (Ep-Fe/Zn 5/CM2)

■ Adaptor: 110, 145, 190, 130, C70, C74, C79

Part No.	Size No.	G	C	Min. I.D. øD	H	L <sub>1</sub>	L <sub>2</sub>	X (HEX)	Wt. (g)	Pusher	Die
★ SF90-PF-10-N30	10	3/4	19.0	13.1	9.5	105	77	32	360	PFB-02+PHB-12	SPN-10

■ Material: steel

■ Surface finishing: zinc electro-galvanized with color chromating (Ep-Fe/Zn 5/CM2)

■ Adaptor: 110, 145, 190, 130, C70, C74, C79

★ Made-to-order

# 3R80 Series

## 3R80

### Features

- Excellent oil and chemical durability
- JIS K 6375 A certified, SAE 100R8 certified.

Nonconductive hose with high electrical insulation is also available. Contact us for details.

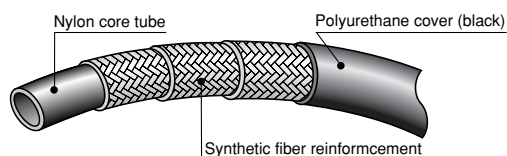

Part No.	Size No.	I.D.		O.D. (mm)	Max. working press. (MPa)	Max. impact press. (MPa)	Min. destruction press. (MPa)	Min. bending radius (mm)	Weight (g/m)	Coupling
		(in.)	(mm)							
3R80-03	03	3/16	4.8	12.7	35.0	46.6	140.0	38	115	Swage
* 3R80-04	04	1/4	6.3	15.5	35.0	46.6	140.0	51	175	
* 3R80-06	06	3/8	9.5	19.1	28.0	37.3	112.0	64	221	
* 3R80-08	08	1/2	12.7	22.2	25.0	33.3	98.0	102	283	
* 3R80-12	12	3/4	19.0	28.6	16.0	21.3	63.0	165	380	
3R80-16	16	1	25.4	36.9	14.0	18.7	56.0	254	572	

- Appropriate fluid: mineral general operating oil
- Working temperature range: -40 to +100°C
- Length in a package: 100 m for sizes 03, 04, 06, 08, and 50 m for sizes 12, 16
- 👁 Reusable connector is made-to-order.

The \* mark above indicates that the outer wire braid type is available (made-to-order). Contact us for details.

**[Swage]**

△ Caution: The size 06 and 08 coupling for N3000 can also be used, but the swage die must be used for 3R80.

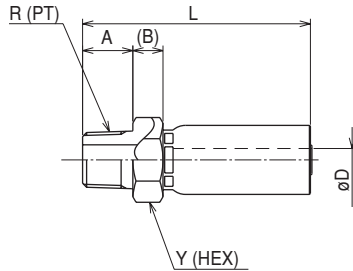
**(For 3R80)****SA**

Part No.	Size No.	R	A	B	Min. I.D. øD	L	Y (HEX)	Wt. (g)	Pusher	Die
SA-PT-03-3R	03	1/4	13	8.5	2.8	53	19	50	PSA-03	SPH-03
SA-PT-04-3R	04	1/4	14	8.5	3.9	61	19	60	PSA-04	SPH-04
SA-PT-06-N30	06	3/8	15	9.0	6.8	67	22	90	PSA-06	SPH-06
SA-PT-08-N30	08	1/2	18	10.0	10.0	76	27	140	PSA-08	SPH-08
SA-PT-12-3R	12	3/4	20	10.0	16.0	83	36	220	PSA-12	SPH-12
SA-PT-16-3R	16	1	23	10.0	20.9	100	41	340	PSA-16	SPH-16

- Material: steel
- Surface finishing: zinc electro-galvanized with color chromating (Ep-Fe/Zn 5/CM2)
- Adaptor: 030, 130

**Stainless type**

Part No.	Size No.	R	A	B	Min. I.D. øD	L	Y (HEX)	Wt. (g)	Pusher	Die	
										First	Second
SA-PT-04-3R-S	04	1/4	14	8.5	3.9	61	19	72	PSA-04	SPH-04-1-ST	SPH-04
SA-PT-06-N30-S	06	3/8	15	9.0	6.8	67	22	90	PSA-06	SPH-06-1-ST	SPH-06
SA-PT-08-N30-S	08	1/2	18	10.0	10.0	76	27	140	PSA-08	SPH-08-1-ST	SPH-08

- Material: stainless steel SUS304
- Adaptor: 030, 130

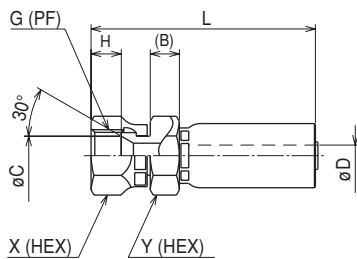
**SE**

Part No.	Size No.	G	B	C	Min. I.D. øD	H	L	X (HEX)	Y (HEX)	Wt. (g)	Pusher	Die
SE-PF-03-3R	03	1/4	6.0	9.5	2.8	8.0	55	19	19	60	PSE-03	SPH-03
SE-PF-04-3R	04	1/4	8.5	9.5	3.9	8.0	63	19	19	80	PSE-04	SPH-04
SE-PF-06-N30	06	3/8	9.5	12.5	6.8	9.5	71	22	22	110	PSE-06	SPH-06
SE-PF-08-N30	08	1/2	9.0	15.5	10.0	12.5	80	27	27	170	PSE-08	SPH-08
SE-PF-12-3R	12	3/4	10.5	21.5	16.0	13.0	87	36	36	280	PSE-12	SPH-12
SE-PF-16-3R	16	1	11.0	27.5	20.9	15.0	105	41	41	400	PSE-16	SPH-16

- Material: steel
- Surface finishing: zinc electro-galvanized with color chromating (Ep-Fe/Zn 5/CM2)
- Adaptor: 010, 045, 090, 150, 020, 025, 064, 069, 030, D70, D74, D79

**Stainless type**

Part No.	Size No.	G	B	C	Min. I.D. øD	H	L	X (HEX)	Y (HEX)	Wt. (g)	Pusher	Die	
												First	Second
SE-PF-04-3R-S	04	1/4	8.5	9.5	3.9	8.0	63	19	19	80	PSE-04	SPH-04-1-ST	SPH-04
SE-PF-06-N30-S	06	3/8	9.5	12.5	6.8	9.5	71	22	22	110	PSE-06	SPH-06-1-ST	SPH-06
SE-PF-08-N30-S	08	1/2	9.0	15.5	10.0	12.5	80	27	27	170	PSE-08	SPH-08-1-ST	SPH-08
SE-PF-12-3R-S	12	3/4	10.5	21.5	16.0	13.0	87	36	36	280	PSE-12	SPH-12-1-ST	SPH-12
SE-PF-16-3R-S	16	1	11.0	27.5	20.9	15.0	105	41	41	400	PSE-16	SPH-16-1-ST	SPH-16

- Material: stainless steel SUS304
- Adaptor: 010, 045, 090, 150, 020, 025, 064, 069, 030, D70, D74, D79

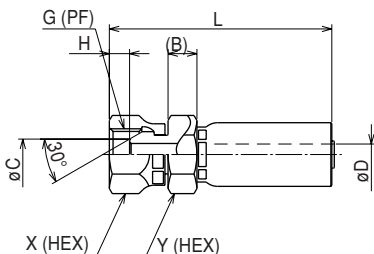
**SF**

Part No.	Size No.	G	B	C	Min. I.D. øD	H	L	X (HEX)	Y (HEX)	Wt. (g)	Pusher	Die
SF-PF-03-3R	03	1/4	6.0	7.5	2.8	5.5	55	19	19	60	PSE-03	SPH-03
SF-PF-04-3R	04	1/4	8.5	7.5	3.9	5.5	63	19	19	80	PSE-04	SPH-04
SF-PF-06-N30	06	3/8	9.5	10.0	6.8	6.5	71	22	22	110	PSE-06	SPH-06
SF-PF-08-N30	08	1/2	9.0	14.0	10.0	9.0	80	27	27	170	PSE-08	SPH-08
SF-PF-12-3R	12	3/4	10.5	19.0	16.0	9.5	87	36	36	280	PSE-12	SPH-12
SF-PF-16-3R	16	1	11.0	25.4	20.9	10.0	105	41	41	410	PSE-16	SPH-16

- Material: steel
- Surface finishing: zinc electro-galvanized with color chromating (Ep-Fe/Zn 5/CM2)
- Adaptor: 110, 145, 190, 130, C70, C74, C79

**[Swage]**

△ Caution: The size 06 and 08 coupling for N3000 can also be used, but the swage die must be used for 3R80.

**(For 3R80)**

**SC**

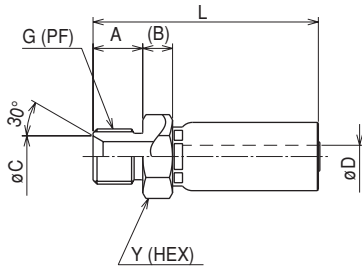

Part No.	Size No.	G	A	B	C	Min. I.D. øD	L	Y (HEX)	Wt. (g)	Pusher	Die
★ SC-PF-03-3R	03	1/4	13	8.5	9.5	2.8	53	19	50	PSA-04	SPH-03
SC-PF-04-3R	04	1/4	14	8.5	9.5	3.9	61	19	60	PSA-04	SPH-04
SC-PF-06-N30	06	3/8	15	9.0	12.5	6.8	67	22	90	PSA-06	SPH-06
★ SC-PF-08-N30	08	1/2	18	10.0	16.5	10.0	76	27	140	PSA-08	SPH-08

- Material: steel
- Surface finishing: zinc electro-galvanized with color chromating (Ep-Fe/Zn 5/CM2)
- Adaptor: 060
- ★ Made-to-order

Hydraulic  
Hose

Airtless-  
painting  
Hose

Clean  
Hose

Natural-Gas  
Hose

Adaptor

Hose Guard  
Part, Specially-  
Treated Part

Assembling  
Machine,  
Jig, Tool

Hose  
Assembling  
Method

Technical  
Document

Reference  
Document

# 5501 Series of electrostatic-free type

5501

## Features

- Electrostatic free
- Excellent chemical durability
- Flexible and tough
- External-damage durability due to stainless wire braid in the reinforcement layer

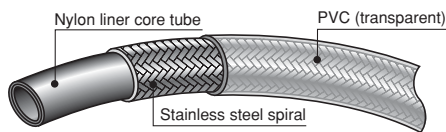

Part No.	Size			Max. working press. (MPa)	Min. destruction press. (MPa)	Min. bending radius (mm)	Weight (g/m)	Coupling	
	Size No.	I.D.							O.D.
		(in.)	(mm)	(mm)					
5501-04-CL	04	1/4	6.0	10.6	21.0	84.0	50	110	Swage
5501-06-CL	06	3/8	9.5	14.8	21.0	84.0	80	220	

- Appropriate fluid: paint, thinner
- Working temperature range: -10 to +60°C
- Assembly operation should be done at Aitta Moore factory.
- "CL" stands for clear.

# 3450 Series of conductive polymer structure type

## Features

- Wireless structure in conductive polymer layer
- Light
- High chemical durability

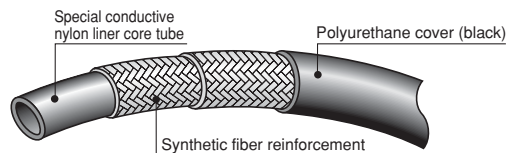

Part No.	Size			Max. working press. (MPa)	Min. destruction press. (MPa)	Min. bending radius (mm)	Weight (g/m)	Coupling	
	Size No.	I.D.							O.D.
		(in.)	(mm)	(mm)					
3450-03	03	3/16	4.8	10.8	23.0	92.0	25	71	Swage
3450-04	04	1/4	6.3	13.2	23.0	92.0	25	95	
★ 3450-06	06	3/8	9.5	18.5	21.0	84.0	60	195	

- Appropriate fluid: paint, thinner
- Working temperature range: -40 to +80°C
- Assembly operation should be done at Aitta Moore factory
- ★ Made-to-order

[Swage]

(For 5501)

SF < For 5501 >

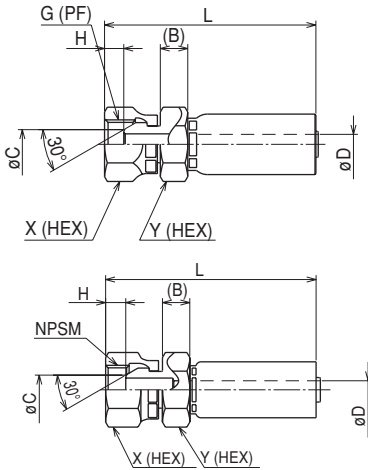

Part No.	Size No.	G or NPSM	B	C	Min. I.D. øD	H	L	X (HEX)	Y (HEX)	Weight (g)
SF-PF-04-55	04	G1/4	8.5	7.5	3.3	5.5	60	19	17	80
SF-NPSM-04-55	04	NPSM1/4	8.5	7.5	3.3	5.5	60	19	17	80
SF-PF-06-5501	06	G3/8	9.5	10.0	6.2	6.5	71	22	22	110
SF-NPSM-06-5501	06	NPSM3/8	9.5	10.0	6.2	6.5	71	22	22	110

- Material: steel
- Surface finishing: zinc electro-galvanized with color chromating (Ep-Fe/Zn 5/CM2)
- Adaptor: 110, 145, 190, 130, C70, C74, C79 \*Not suitable for NPSM
- Assembly of couplings with hose is to be done at our factory.

(For 3450)

SF < For 3450 >

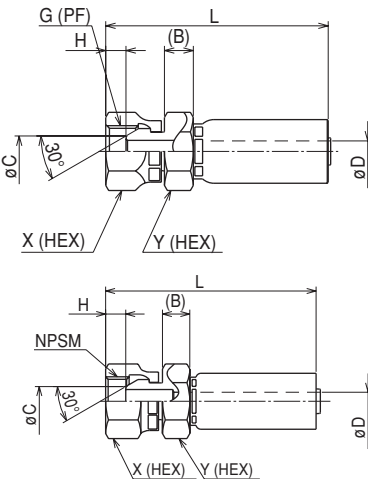

Part No.	Size No.	G or NPSM	B	C	Min. I.D. øD	H	L	X (HEX)	Y (HEX)	Weight (g)
SF-PF-03	03	1/4	6.0	7.5	2.8	5.5	58	19	19	70
SF-NPSM-03-3450	03	NPSM1/4	6.0	7.5	3.0	4.0	56	19	19	70
SF-PF-04	04	1/4	8.5	7.5	3.9	5.5	63	19	19	80
SF-NPSM-04	04	NPSM1/4	8.5	7.5	4.0	5.5	63	19	19	80
SF-PF-06-N30	06	3/8	9.5	10.0	6.8	6.5	71	22	22	110

- Material: steel
- Surface finishing: zinc electro-galvanized with color chromating (Ep-Fe/Zn 5/CM2)
- Adaptor: 110, 145, 190, 130, C70, C74, C79
- Assembly of couplings with hose is to be done at our factory.



# 34PW Series

For pure water, urethane forming m/c, food, or drinking water

## 34PW

### Features

- High water-barrier performance
- Excellent chemical durability
- Anti-taint property
- Sanitary, because of the material that matches the FDA standard and complies with No.20 of the Ministry of welfare, Japan.

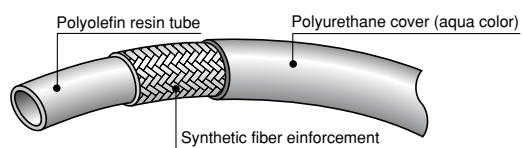

Part No.	Size No.	Size			Max. working press. (MPa)	Max. impact press. (MPa)	Min. destruction press. (MPa)	Min. bending radius (mm)	Weight (g/m)	Coupling
		I.D. (in.)	I.D. (mm)	O.D. (mm)						
34PW-02-LBU	02	1/8	3.6	8.3	20.0	25.0	80.0	25	45	Swage
34PW-04-LBU	04	1/4	6.3	12.5	19.5	24.4	78.0	30	95	
34PW-06-LBU	06	3/8	9.5	16.4	16.0	20.0	64.0	50	134	
34PW-08-LBU	08	1/2	12.7	20.3	14.0	17.5	56.0	75	241	
34PW-12-LBU	12	3/4	19.0	28.7	10.5	13.2	42.0	125	368	
34PW-16-LBU	16	1	25.4	36.5	10.5	13.2	42.0	200	554	

- Appropriate fluid: pure water, chemicals (isocyanate), etc.
  - Working temperature range: -30 to +70°C
  - Assembly operation should be done at our factory.
- ☞ Each pressure in the above table represents a pressure with the use of a PW coupling.  
 ☞ "-LBU" stands for light blue.

[Swage]

(For 34PW)

## SE < PW coupling >

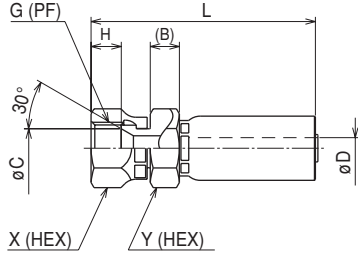

### Stainless (SUS316)

Part No.	Size No.	G	B	C	Min. I.D. øD	H	L	X (HEX)	Y (HEX)	Wt. (g)	Pusher	Die	
												First	Second
SE-G-04-PW	04	1/4	8.5	9.0	4.0	8.0	63	19	19	80	PSE-04	SP3-04-VC	—
SE-G-06-PW	06	3/8	9.5	12.0	6.9	9.0	71	22	22	110	PSE-06	SP3-06-VC	—
SE-G-08-PW	08	1/2	9.0	15.5	10.0	12.5	80	27	27	170	PSE-08	SP3-08-VC	—
SE-G-12-PW	12	3/4	10.0	21.0	16.0	13.5	86	36	36	270	PSE-12	SPH-12-1-ST	SPH-12-VC
SE-G-16-PW	16	1	11.0	28.0	20.9	16.5	105	41	41	410	PSE-16	SPH-16-1-ST	SPH-16-37VC

- Material: stainless steel SUS316
- Assembly of couplings with hose is to be done at our factory.
- ☞ Ultrasonic cleaning is available only for the couplings, if required. Contact us for details.
- ☞ As for the steel couplings; sizes 04, 06, and 08 for N3130 series, and sizes 12 and 16 for 3R80 can also be used.

## SE < PWL coupling > for under 7.0 MPa

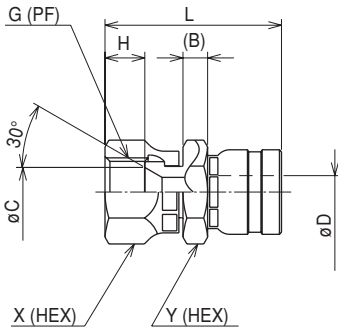

### Stainless (SUS316)

Part No.	Size No.	G	B	C	Min. I.D. øD	H	L	X (HEX)	Y (HEX)	Wt. (g)	Pusher	Die
SE-G-04-PWL	04	1/4	6.0	9.0	5.0	8.0	42	19	19	60	PSE-04-PWL	SPP-04-VC
SE-G-06-PWL	06	3/8	6.0	12.0	8.0	9.5	44	22	22	70	PSE-06-PWL	SPP-06-VC
SE-G-08-PWL	08	1/2	8.0	15.5	11.0	12.5	54	27	27	130	PSE-08-PWL	SPP-08-VC
SE-G-12-PWL	12	3/4	10.0	21.0	16.0	13.5	64	36	36	230	PSE-12-PWL	SPP-12-VC
SE-G-16-PWL	16	1	10.0	28.0	22.0	16.5	67	41	41	310	PSE-16-PWL	SPP-16-VC

- Maximum working pressure (static pressure): 7.0MPa
- Material: stainless steel SUS316
- Assembly of couplings with hose is to be done at our factory.
- ☞ Ultrasonic cleaning is available only for the couplings, if required. Contact us for details.
- ☞ As for the steel couplings; sizes 04, 06, and 08 for N3130 series, and sizes 12 and 16 for 3R80 can also be used.

## SE

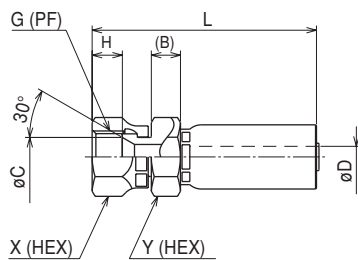

### Stainless (SUS304)

Part No.	Size No.	G	B	C	Min. I.D. øD	H	L	X (HEX)	Y (HEX)	Wt. (g)	Pusher	Die	
												First	Second
SSE-PF-02-S	02	1/8	4.0	7.0	1.8	7.0	42	14	14	25	PSE-02-001	SP3-02-001	—
SE-PF-04-S	04	1/4	8.5	9.5	3.9	8.0	63	19	19	80	PSE-04	SP3-04-1-ST	SP3-04
SE-PF-06-S	06	3/8	9.5	12.5	6.8	9.5	71	22	22	110	PSE-06	SP3-06-1-ST	SP3-06
SE-PF-08-S	08	1/2	9.0	16.0	10.0	12.0	80	27	27	170	PSE-08	SP3-08-1-ST	SP3-08
SE-PF-12-3R-S	12	3/4	10.5	21.5	16.0	13.0	87	36	36	280	PSE-12	SPH-12-1-ST	SPH-12
SE-PF-16-3R-S	16	1	11.0	27.5	20.9	15.0	105	41	41	400	PSE-16	SPH-16-1-ST	SPH-16

- Material: stainless steel SUS304
- Assembly of couplings with hose is to be done at our factory.
- ☞ Ultrasonic cleaning is available only for the couplings, if required. Contact us for details.
- ☞ As for the steel coupling, size 02 for 3130 series, sizes 04, 06, and 08 for N3130 series, and sizes 12 and 16 for 3R80 can also be used.

## Adaptor for 34PW

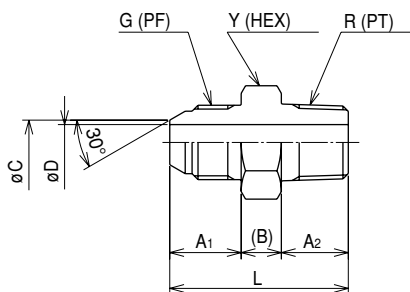

### Stainless (SUS316)

Part No.	Size No.	G	R	A <sub>1</sub>	A <sub>2</sub>	B	C	Min. I.D. øD	L	Y (HEX)	Wt. (g)
010-4-4-PW	04	1/4	1/4	13	14	8.0	7.0	5.5	35	19	40
010-6-6-PW	06	3/8	3/8	16	15	9.0	10.0	8.0	40	22	60
010-8-8-PW	08	1/2	1/2	19	18	10.0	13.0	11.0	47	27	100
010-12-12-PW	12	3/4	3/4	21	20	12.0	19.0	16.0	53	36	180
010-16-16-PW	16	1	1	23	23	13.0	25.0	22.0	59	41	250

- Material: stainless steel SUS316
- ☞ Ultrasonic cleaning is available only for the couplings, if required. Contact us for details.

# 35NG Series

For CNG (natural gas)

## 35NG

Made-to-order

### Features

- Light
- Conductive nylon liner core tube used

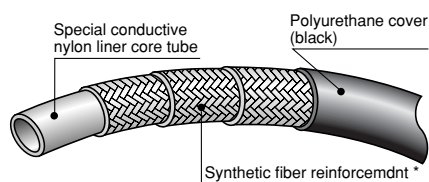

\* Sizes 06 and 08 have a two-layer structure.

Part No.	Size			Max. working press. (MPa)	Hydro-static test press. (MPa)	4-times hydro-static test press. (MPa)	Min. destruction press. (MPa)	Electric resistivity <sup>*1</sup> (kΩ/m)	Min. bending radius (mm)	Wt. (g/m)	Coupling	
	Size No.	I.D. (in.)	I.D. (mm)									O.D. (mm)
★ 35NG-04	04	1/4	6.4	16.0	22.0	33.0	88.0	140.0	Max. 130	50	173	
★ 35NG-06	06	3/8	9.7	19.5	28.0	42.0	112.0	140.0	Max. 110	100	226	Swage
★ 35NG-08	08	1/2	12.8	22.5	28.0	42.0	112.0	140.0	Max. 50	140	140	

- Appropriate fluid: CNG (natural gas)
- ☞ Contact us for other gas.
- Working temperature range: -40 to +66°C
- Assembly of couplings with a hose is to be done at our factory.
- \*1 Applied voltage: 250V
- ☞ Four-times hydrostatic test can be performed as a separate test with an additional fee at our laboratory.
- ★ Made-to-order

[Swage]

(For 35NG)

SA

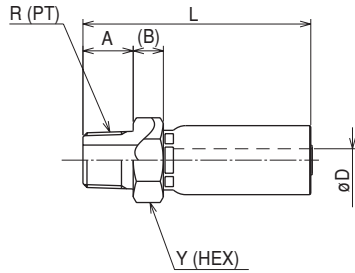

## Stainless

Part No.	Size No.	R	A	B	Min. I.D. øD	L	Y (HEX)	Weight (g)
SA-PT-04-3R-S-CNG	04	1/4	13	8.5	3.9	60	19	60
SA-PT-06-N30-S	06	3/8	15	9.0	6.8	67	22	90
SA-PT-08-N30-S	08	1/2	18	10.0	10.0	76	27	140

■ Material: stainless steel SUS304

■ Assembly of couplings with hose is to be done at our factory.

SE

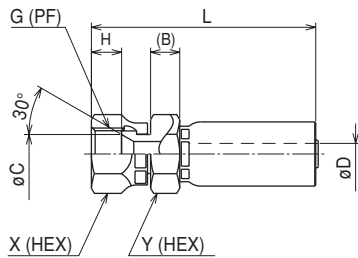

## Stainless

Part No.	Size No.	G	B	C	Min. I.D. øD	H	L	X (HEX)	Y (HEX)	Weight (g)
SE-PF-04-3R-S-CNG	04	1/4	8.0	9.0	3.9	8.0	64	19	19	80
SE-PF-06-N30-S	06	3/8	9.5	12.5	6.8	9.5	71	22	22	110
SE-PF-08-N30-S	08	1/2	9.0	15.5	10.0	12.5	80	27	27	170

■ Material: stainless steel SUS304

■ Assembly of couplings with hose is to be done at our factory.

# Adaptor Products

**Adaptor** **54**

**Adaptor shapes chart** **55**



How to assemble  
P.89

## Specification

Material: Steel (Zinc electrogalvanized with color chromating. Ep-Fe/Zn5/CM2), SUS304, SUS316

## Usage conditions

Appropriate fluid: Mineral hydraulic oil

Maximum working pressure: It changes with the size of G- and R-threads, and when different sizes exist in one product, the larger one is to be counted.

(taper thread type to the equipment side or interconnection type)

02 to 08 : 35.0MPa

12 : 27.5MPa

16 : 20.5MPa

(parallel thread type to the equipment side)

04 to 12 : 21.0MPa

16 : 10.5MPa

Working temperature range: (Taper thread type to the equipment side or interconnection type to the equipment)

-55°C to +120°C

(Parallel thread type to the equipment side)

-30°C to +100°C

## Example of part number

**010 - 04 - 04 - (S)**

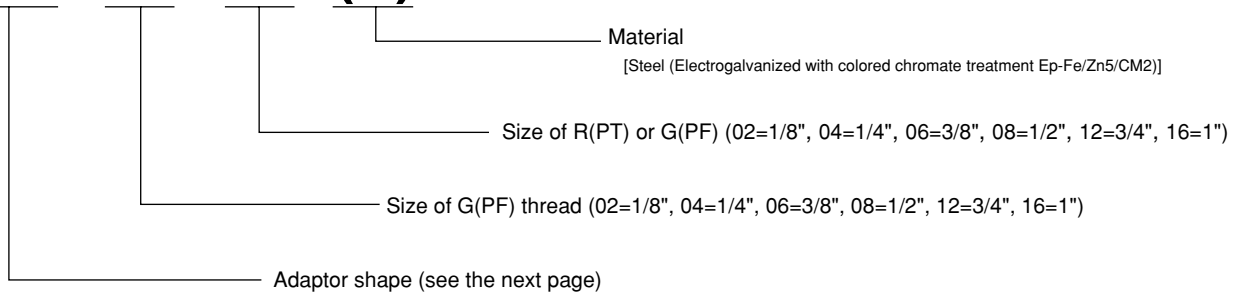

## Taper thread type to equipment side (with 30° female seat)

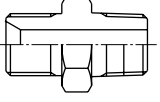
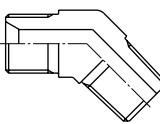
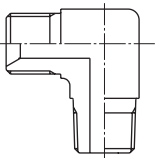
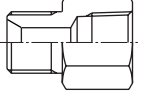
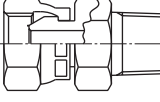
Straight type	45° elbow type	90° elbow type	Female-thread straight type	Parallel male-thread type
110	145	190	130	060
				

## Taper thread type to equipment side (with 30° male seat)

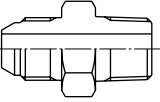
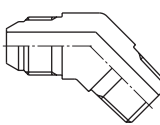
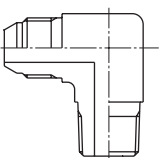
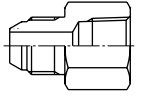
Straight type	45° elbow type	90° elbow type	Female-thread straight type
010	045	090	030
			

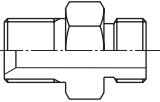
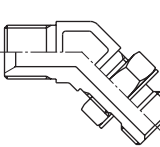
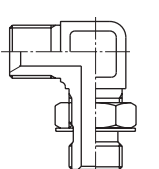

## Parallel thread type to equipment side (with 30° female seat)

Straight type	45° elbow type	90° elbow type
C70	C74	C79
		

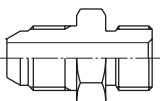
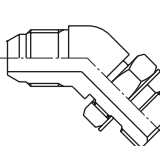
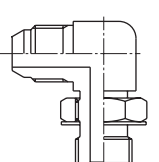
## Parallel thread type to equipment side (with 30° male seat)

Straight type	45° elbow type	90° elbow type
D70	D74	D79
		

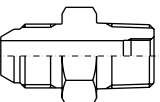
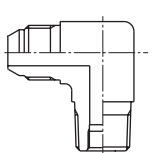
## Taper thread screw type to equipment side (with 30° male seat)

Straight type	90° elbow type	Thread screw bolt
010-001	090-001	007
		

## Interconnection type (with 30° male seat)

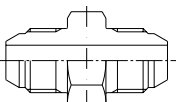
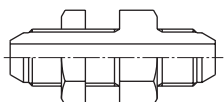
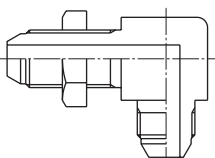
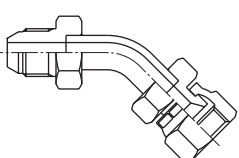
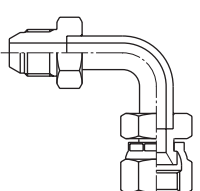
Straight type	Panel touch straight type	Panel touch 90° straight type	45° bend type	90° bend type
150	020	025	064	069
				

Contact us for other shapes.

Hydraulic  
Hose

Airless-  
painting  
Hose

Clean  
Hose

Natural-Gas  
Hose

Adaptor

Hose Guard  
Part, Specially-  
Treated Part

Assembling  
Machine,  
Jig, Tool

Hose  
Assembling  
Method

Technical  
Document

Reference  
Document



## Taper thread type to equipment side (with 30° female seat)

# 110

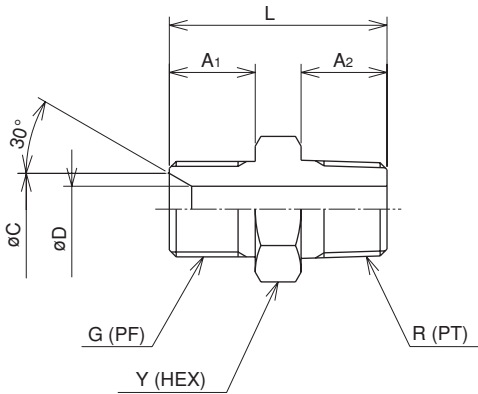

Part No.	G	R	A <sub>1</sub>	A <sub>2</sub>	C	Min. I.D. øD	L	Y (HEX)	Weight (g)
110-02-02	1/8	1/8	10	10	7.0	3.0	28	14	20
110-02-04	1/8	1/4	10	13	7.0	3.0	31	17	30
110-04-02	1/4	1/8	13	10	9.0	5.5	31	19	30
110-04-04	1/4	1/4	13	13	9.5	5.0	34	19	35
110-04-06	1/4	3/8	13	15	9.0	5.5	36	22	50
110-06-04	3/8	1/4	15	13	12.5	5.0	36	22	50
110-06-06	3/8	3/8	15	15	12.5	8.0	38	22	55
110-06-08	3/8	1/2	15	18	12.5	8.0	43	27	90
110-08-06	1/2	3/8	18	15	15.5	11.0	43	27	90
110-08-08	1/2	1/2	18	18	16.0	11.0	46	27	100
110-08-12	1/2	3/4	18	20	15.5	10.0	50	36	165
110-12-08	3/4	1/2	20	18	21.0	16.0	50	36	165
110-12-12	3/4	3/4	20	20	21.5	16.0	52	36	175
110-12-16	3/4	1	20	22	21.0	16.0	54	41	235
110-16-12	1	3/4	22	20	27.5	22.0	56	41	235
110-16-16	1	1	22	22	27.5	22.0	57	41	245

■ Material: steel

■ Surface finishing: zinc electro-galvanized with color chromating (Ep-Fe/Zn 5/CM2)

### Stainless type

Part No.	G	R	A <sub>1</sub>	A <sub>2</sub>	C	Min. I.D. øD	L	Y (HEX)	Weight (g)
110-02-02-S	1/8	1/8	10	10	7.0	3.0	28	14	20
110-04-04-S	1/4	1/4	13	13	9.5	5.0	34	19	35
110-06-06-S	3/8	3/8	15	15	12.5	8.0	38	22	55
110-08-08-S	1/2	1/2	18	18	16.0	11.0	46	27	100
110-12-12-S	3/4	3/4	20	20	21.5	16.0	52	36	175
110-16-16-S	1	1	22	22	27.5	22.0	57	41	245

■ Material: stainless steel SUS304

### Hose couplings:

SF, SL, SF45, SF90, AF45, AF90, CF, F

# 145

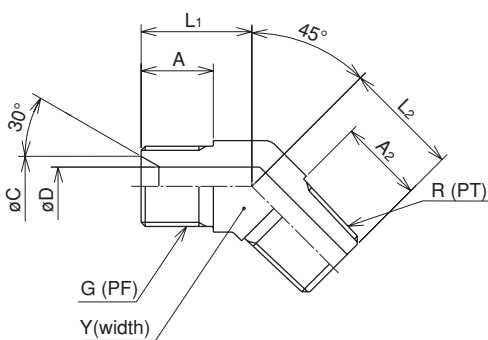

Part No.	G	R	A <sub>1</sub>	A <sub>2</sub>	C	Min. I.D. øD	L <sub>1</sub>	L <sub>2</sub>	Y (width)	Weight (g)
145-02-02	1/8	1/8	14	14	7.0	3.0	18	18	14	20
★ 145-02-04	1/8	1/4	10	13	7.0	3.0	18	20	17	35
★ 145-04-02	1/4	1/8	13	14	9.0	5.5	19	20	17	36
145-04-04	1/4	1/4	13	14	9.0	5.5	19	20	17	40
★ 145-04-06	1/4	3/8	13	18	9.0	8.0	18	24	19	55
★ 145-06-04	3/8	1/4	15	14	12.5	8.0	23	21	19	57
145-06-06	3/8	3/8	15	15	12.5	8.0	23	24	19	65
★ 145-06-08	3/8	1/2	15	18	12.5	11.0	23	27	24	99
★ 145-08-06	1/2	3/8	18	15	16.0	11.0	26	24	24	95
145-08-08	1/2	1/2	18	22	15.5	11.0	26	27	24	100
★ 145-08-12	1/2	3/4	18	20	16.0	16.0	26	32	30	170
★ 145-12-08	3/4	1/2	20	18	21.5	16.0	32	27	30	170
145-12-12	3/4	3/4	20	20	21.5	16.0	32	32	30	190
★ 145-12-16	3/4	1	20	22	21.5	22.0	32	34	36	264
★ 145-16-12	1	3/4	22	20	27.5	22.0	35	32	36	250
145-16-16	1	1	22	22	28.0	22.0	35	34	36	275

■ Material: steel

■ Surface finishing: zinc electro-galvanized with color chromating (Ep-Fe/Zn 5/CM2)

★ Made-to-order

### Hose couplings:

SF, SL, SF45, SF90, AF45, AF90, CF, F

## Taper thread type to equipment side (with 30° female seat)

# 190

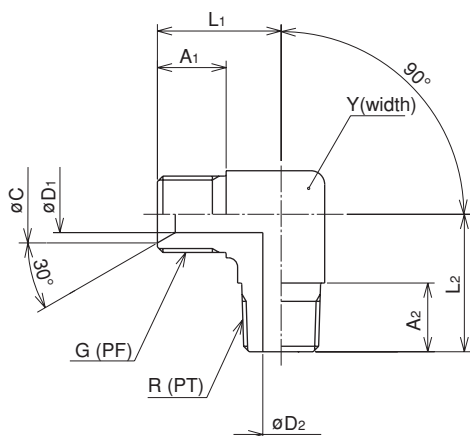

Part No.	G	R	A <sub>1</sub>	A <sub>2</sub>	C	D <sub>1</sub>	D <sub>2</sub>	L <sub>1</sub>	L <sub>2</sub>	Y (width)	Weight (g)
190-02-02	1/8	1/8	9	14	7.0	3.0	4.0	18	22	14	30
190-02-04	1/8	1/4	10	13	7.0	3.0	5.0	20	27	17	50
190-04-02	1/4	1/8	13	10	9.5	6.0	4.0	25	20	17	45
190-04-04	1/4	1/4	13	13	9.5	5.0	5.0	23	27	17	50
190-04-06	1/4	3/8	13	18	9.0	5.5	8.0	25	30	19	80
190-06-04	3/8	1/4	15	16	12.5	8.0	5.5	27	28	19	75
190-06-06	3/8	3/8	15	15	12.5	8.0	8.0	27	30	19	145
190-06-08	3/8	1/2	15	22	12.5	8.0	11.0	28	38	24	140
190-08-06	1/2	3/8	18	20	15.5	11.0	8.0	31	32	24	140
190-08-08	1/2	1/2	18	18	16.0	11.0	11.0	31	38	24	165
190-08-12	1/2	3/4	18	24	15.5	11.0	16.0	34	43	30	250
190-12-08	3/4	1/2	20	22	21.0	16.0	11.0	36	41	30	250
190-12-12	3/4	3/4	20	20	21.5	16.0	16.0	36	43	30	265
190-12-16	3/4	1	20	22	21.5	16.0	22.0	42	46	36	400
190-16-12	1	3/4	22	20	27.5	22.0	16.0	42	43	36	400
190-16-16	1	1	22	27	27.5	22.0	22.0	42	46	36	460

■ Material: steel

■ Surface finishing: zinc electro-galvanized with color chromating (Ep-Fe/Zn 5/CM2)

### Stainless type

Part No.	G	R	A <sub>1</sub>	A <sub>2</sub>	C	D <sub>1</sub>	D <sub>2</sub>	L <sub>1</sub>	L <sub>2</sub>	Y (HEX)	Weight (g)
190-02-02-S	1/8	1/8	9	14	7.0	3.0	4.0	18	22	14	30
190-04-04-S	1/4	1/4	13	13	9.5	5.0	5.0	23	27	17	50
190-06-06-S	3/8	3/8	15	15	12.5	8.0	8.0	27	30	19	145
190-08-08-S	1/2	1/2	18	18	16.0	11.0	11.0	31	38	24	165
190-12-12-S	3/4	3/4	20	20	21.5	16.0	16.0	36	43	30	265
190-16-16-S	1	1	22	27	27.5	22.0	22.0	42	46	36	460

■ Material: stainless steel SUS304

### Hose couplings:

SF, SL, SF45, SF90, AF45, AF90, CF, F

# 130

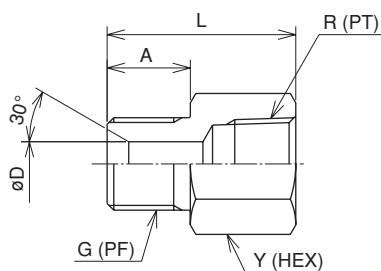

Part No.	G	R	A	C	Min. I.D. øD	L	Y (HEX)	Weight (g)
130-02-02	1/8	1/8	10	7.0	3.0	25	14	18
130-04-04	1/4	1/4	13	9.0	5.5	30	19	36
130-06-06	3/8	3/8	15	12.5	8.0	34	22	52
130-08-08	1/2	1/2	18	15.5	11.0	40	27	88
130-12-12	3/4	3/4	20	21.0	16.0	45	36	175
130-16-16	1	1	22	28.0	22.0	50	41	221

■ Material: steel

■ Surface finishing: zinc electro-galvanized with color chromating (Ep-Fe/Zn 5/CM2)

### Hose couplings: SA, SF, SL, SF45, SF90, AF45, AF90, CA, CF, A, F

# 060

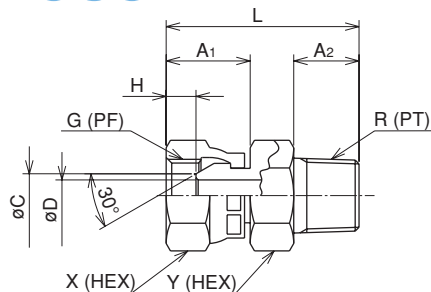

Part No.	G	R	A <sub>1</sub>	A <sub>2</sub>	C	Min. I.D. øD	H	L	X (HEX)	Y (HEX)	Weight (g)
060-02-02	1/8	1/8	16.0	11	5.0	2.8	3.0	35	14	14	25
060-04-04	1/4	1/4	17.0	13	7.0	5.0	5.5	38	19	19	50
060-06-06	3/8	3/8	19.0	15	10.0	7.2	6.5	44	22	22	80
060-08-08	1/2	1/2	23.5	18	13.2	11.0	9.5	52	27	27	115
060-12-12	3/4	3/4	23.5	21	19.0	16.0	9.5	57	36	36	220
060-16-16	1	1	27.0	23	25.4	21.5	10.0	63	41	41	300

■ Material: steel

■ Surface finishing: zinc electro-galvanized with color chromating (Ep-Fe/Zn 5/CM2)

### Hose couplings: SC

## Taper thread type to equipment side (with 30° female seat)

# 010

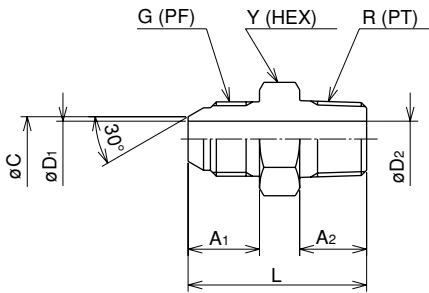

Part No.	G	R	A <sub>1</sub>	A <sub>2</sub>	C	D <sub>1</sub>	D <sub>2</sub>	L	Y (HEX)	Weight (g)
010-02-02	1/8	1/8	12	10	4.5	3.0	3.0	30	14	20
010-02-04	1/8	1/4	12	13	4.5	3.0	5.5	34	17	30
010-04-02	1/4	1/8	14	10	7.5	5.5	3.0	32	19	30
010-04-04	1/4	1/4	14	13	7.5	5.5	5.5	35	19	35
010-04-06	1/4	3/8	14	15	7.5	5.5	8.0	37	22	50
010-06-04	3/8	1/4	16	13	10.0	8.0	5.5	39	22	50
010-06-06	3/8	3/8	16	15	10.0	8.0	8.0	40	22	55
010-06-08	3/8	1/2	16	18	10.0	8.0	11.0	44	27	85
010-08-06	1/2	3/8	19	15	13.0	11.0	8.0	44	27	85
010-08-08	1/2	1/2	19	18	13.0	11.0	11.0	47	27	95
010-08-12	1/2	3/4	19	20	13.0	11.0	16.0	53	36	160
010-12-08	3/4	1/2	21	18	19.0	16.0	11.0	51	36	160
010-12-12	3/4	3/4	21	20	19.0	16.0	16.0	53	36	170
010-12-16	3/4	1	21	22	19.0	16.0	22.0	56	41	230
010-16-12	1	3/4	23	20	25.0	22.0	16.0	56	41	230
010-16-16	1	1	23	22	25.0	22.0	22.0	58	41	235

- Material: steel
- Surface finishing: zinc electro-galvanized with color chromating (Ep-Fe/Zn 5/CM2)

### Stainless type

Part No.	G	R	A <sub>1</sub>	A <sub>2</sub>	C	D <sub>1</sub>	D <sub>2</sub>	L	Y (HEX)	Weight (g)
010-02-02-S	1/8	1/8	12	10	4.5	3.0	3.0	30	14	20
010-04-04-S	1/4	1/4	14	13	7.5	5.5	5.5	35	19	35
010-06-06-S	3/8	3/8	16	15	10.0	8.0	8.0	40	22	55
010-08-08-S	1/2	1/2	19	18	13.0	11.0	11.0	47	27	95
010-12-12-S	3/4	3/4	21	20	19.0	16.0	16.0	53	36	170
010-16-16-S	1	1	23	22	25.0	22.0	22.0	58	41	235

- Material: stainless steel SUS304

### Hose couplings:

SE, SLE, SE45, SE90, AE45, AE90, CE, E

# 045

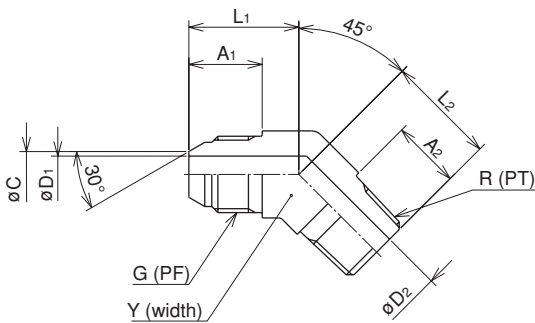

Part No.	G	R	A <sub>1</sub>	A <sub>2</sub>	C	D <sub>1</sub>	D <sub>2</sub>	L <sub>1</sub>	L <sub>2</sub>	Y (width)	Weight (g)
045-02-02	1/8	1/8	12	10	4.5	3.0	3	18	18	14	20
045-02-04	1/8	1/4	12	13	4.5	3.0	5	20	20	17	35
045-04-02	1/4	1/8	16	14	7.0	5.5	3	22	18	17	35
045-04-04	1/4	1/4	14	13	7.5	5.0	5	22	20	17	40
045-04-06	1/4	3/8	16	18	7.0	5.5	8	22	24	19	60
045-06-04	3/8	1/4	16	13	10.0	8.0	5	24	20	19	60
045-06-06	3/8	3/8	16	15	10.0	8.0	8	24	24	19	65
045-06-08	3/8	1/2	17	22	10.0	8.0	11	24	27	24	90
045-08-06	1/2	3/8	20	18	13.0	11.0	8	27	24	24	90
045-08-08	1/2	1/2	19	18	13.0	11.0	11	27	27	24	100
045-08-12	1/2	3/4	20	23	13.0	11.0	16	27	32	30	160
045-12-08	3/4	1/2	21	22	19.0	16.0	11	32	27	30	170
045-12-12	3/4	3/4	21	23	19.0	16.0	16	32	32	30	190
045-12-16	3/4	1	21	26	19.0	16.0	22	32	34	36	265
045-16-12	1	3/4	23	23	25.0	22.0	16	35	32	36	265
045-16-16	1	1	23	22	25.0	22.0	22	35	34	36	295

- Material: steel
- Surface finishing: zinc electro-galvanized with color chromating (Ep-Fe/Zn 5/CM2)

### Stainless type

Part No.	G	R	A <sub>1</sub>	A <sub>2</sub>	C	D <sub>1</sub>	D <sub>2</sub>	L <sub>1</sub>	L <sub>2</sub>	Y (width)	Weight (g)
★ 045-02-02-S	1/8	1/8	12	10	4.5	3.0	3	18	18	14	20
★ 045-04-04-S	1/4	1/4	14	13	7.5	5.0	5	22	20	17	40
★ 045-06-06-S	3/8	3/8	16	15	10.0	8.0	8	24	24	19	65
★ 045-08-08-S	1/2	1/2	19	18	13.0	11.0	11	27	27	24	100
★ 045-12-12-S	3/4	3/4	21	23	19.0	16.0	16	32	32	30	190
★ 045-16-16-S	1	1	23	22	25.0	22.0	22	35	34	36	295

- Material: stainless steel SUS304
- ★ Made-to-order

### Hose couplings:

SE, SLE, SE45, SE90, AE45, AE90, CE, E

## Taper thread type to equipment side (with 30° male seat)

### 090

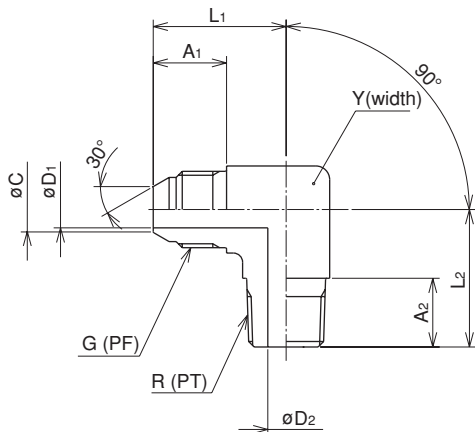

Part No.	G	R	A <sub>1</sub>	A <sub>2</sub>	C	D <sub>1</sub>	D <sub>2</sub>	L <sub>1</sub>	L <sub>2</sub>	Y (width)	Weight (g)
090-02-02	1/8	1/8	14	12	4.5	3.0	4	22	22	14	30
090-02-04	1/8	1/4	12	13	4.5	3.0	5	23	27	17	45
090-04-02	1/4	1/8	14	10	7.5	5.0	3	24	23	17	45
090-04-04	1/4	1/4	14	13	7.5	5.0	5	24	27	17	50
090-04-06	1/4	3/8	16	18	7.5	5.5	8	29	30	19	80
090-06-04	3/8	1/4	16	13	10.0	8.0	5	29	27	19	75
090-06-06	3/8	3/8	16	15	10.0	8.0	8	29	30	19	80
090-06-08	3/8	1/2	16	18	10.0	8.0	11	29	38	24	145
090-08-06	1/2	3/8	20	18	13.0	11.0	8	33	30	24	140
090-08-08	1/2	1/2	20	22	13.0	11.0	11	33	38	24	165
090-08-12	1/2	3/4	20	24	13.0	11.0	16	36	43	30	250
090-12-08	3/4	1/2	21	22	19.0	16.0	11	36	38	30	250
090-12-12	3/4	3/4	21	20	19.0	16.0	16	36	43	30	265
090-12-16	3/4	1	23	25	19.0	16.0	22	42	46	36	400
090-16-12	1	3/4	23	24	25.0	22.0	16	42	43	36	400
090-16-16	1	1	23	22	25.0	22.0	22	42	46	36	400

- Material: steel
- Surface finishing: zinc electro-galvanized with color chromating (Ep-Fe/Zn 5/CM2)

#### Stainless type

Part No.	G	R	A <sub>1</sub>	A <sub>2</sub>	C	D <sub>1</sub>	D <sub>2</sub>	L <sub>1</sub>	L <sub>2</sub>	Y (width)	Weight (g)
090-02-02-S	1/8	1/8	14	12	4.5	3.0	4	22	22	14	30
090-04-04-S	1/4	1/4	14	13	7.5	5.0	5	24	27	17	50
090-06-06-S	3/8	3/8	16	15	10.0	8.0	8	29	30	19	80
090-08-08-S	1/2	1/2	19	18	13.0	11.0	11	33	38	24	165
090-12-12-S	3/4	3/4	21	20	19.0	16.0	16	36	43	30	265
090-16-16-S	1	1	23	22	25.0	22.0	22	42	46	36	400

- Material: stainless steel SUS304

Hose couplings:  
SE, SLE, SE45, SE90, AE45, AE90, CE, E

### 030

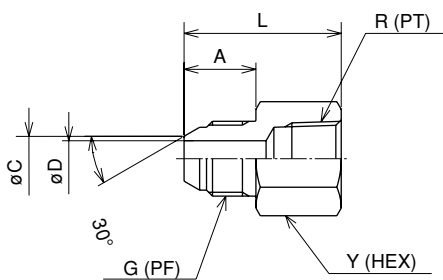

Part No.	G	R	A	C	Min. I.D. øD	L	Y (HEX)	Weight (g)
030-02-02	1/8	1/8	12	4.5	3.0	27	14	20
030-04-04	1/4	1/4	14	7.5	5.5	30	19	25
030-06-06	3/8	3/8	16	10.0	8.0	35	22	55
030-08-08	1/2	1/2	19	13.0	11.0	41	27	75
030-12-12	3/4	3/4	21	19.0	16.0	46	36	160
030-16-16	1	1	23	25.0	22.0	51	41	220

- Material: steel
- Surface finishing: zinc electro-galvanized with color chromating (Ep-Fe/Zn 5/CM2)

#### Stainless type

Part No.	G	R	A	C	Min. I.D. øD	L	Y (HEX)	Weight (g)
★ 030-02-02-S	1/8	1/8	12	4.5	3.0	27	14	20
★ 030-04-04-S	1/4	1/4	14	7.5	5.5	30	19	25
★ 030-06-06-S	3/8	3/8	16	10.0	8.0	35	22	55
★ 030-08-08-S	1/2	1/2	19	13.0	11.0	41	27	75
★ 030-12-12-S	3/4	3/4	21	19.0	16.0	46	36	160
★ 030-16-16-S	1	1	23	25.0	22.0	51	41	220

- Material: stainless steel SUS304
- ★ Made-to-order

Hose couplings: SA, SE, SLE, SE45, SE90, AE45, AE90, CA, CE, A, E

## Parallel thread type to equipment side (with 30° female seat)

### C70

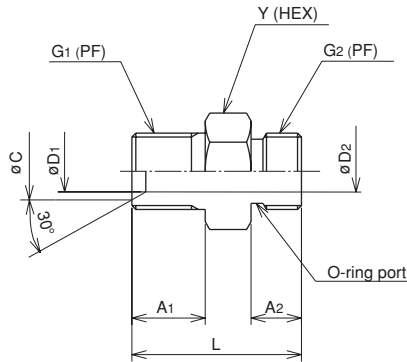

Part No.	G <sub>1</sub>	G <sub>2</sub>	A <sub>1</sub>	A <sub>2</sub>	C	D <sub>1</sub>	D <sub>2</sub>	L	Y (HEX)	Weight (g)	O-ring
C70-04-04	1/4	1/4	13	11	9.5	5.5	5.5	33	19	40	JISB2401P11
★ C70-04-06	1/4	3/8	13	12	9.5	5.5	5.5	33	22	50	JISB2401P14
★ C70-06-04	3/8	1/4	16	10	12.5	5.5	5.5	34	22	50	JISB2401P11
C70-06-06	3/8	3/8	16	11	12.5	9.0	9.0	37	22	55	JISB2401P14
★ C70-06-08	3/8	1/2	16	14	12.5	9.0	9.0	40	27	85	JISB2401P18
★ C70-08-06	1/2	3/8	18	12	16.5	9.0	9.0	40	27	85	JISB2401P14
C70-08-08	1/2	1/2	18	15	16.5	11.2	11.2	43	27	95	JISB2401P18
★ C70-08-12	1/2	3/4	18	16	16.5	11.5	11.5	44	32	135	JISB2401P24
★ C70-12-08	3/4	1/2	20	14	22.0	11.5	11.5	44	32	135	JISB2401P18
C70-12-12	3/4	3/4	20	16	22.0	15.5	15.5	49	32	160	JISB2401P24
★ C70-12-16	3/4	1	20	18	22.0	15.5	15.5	50	41	245	JISB2401P29
★ C70-16-12	1	3/4	22	16	28.0	15.5	15.5	50	41	245	JISB2401P24
C70-16-16	1	1	22	20	28.0	21.0	21.0	56	41	225	JISB2401P29

- Material: steel
- Surface finishing: zinc electro-galvanized with color chromating (Ep-Fe/Zn 5/CM2)
- ★ Made-to-order
- ☒ O-ring is not attached.

## Hose couplings: SF, SL, SF45, SF90, AF45, AF90, CF, F

### C74

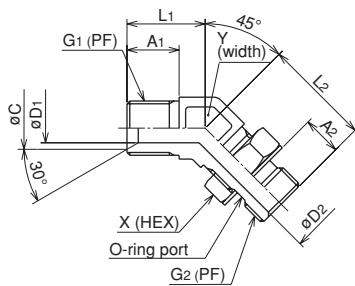

Part No.	G <sub>1</sub>	G <sub>2</sub>	A <sub>1</sub>	A <sub>2</sub>	C	D <sub>1</sub>	D <sub>2</sub>	L <sub>1</sub>	L <sub>2</sub>	X (HEX)	Y (width)	Weight (g)	O-ring
C74-04-04N	1/4	1/4	14	11	9.5	5.5	5.5	19	29	19	14	55	JISB2401P11
★ C74-04-06N	1/4	3/8	14	12	9.5	5.5	9.0	24	33	22	19	85	JISB2401P14
★ C74-06-04N	3/8	1/4	16	11	13.0	9.0	5.5	24	33	19	19	80	JISB2401P11
C74-06-06N	3/8	3/8	16	12	13.0	9.0	9.0	24	33	22	19	80	JISB2401P14
★ C74-06-08N	3/8	1/2	16	14	13.0	9.0	11.5	28	39	27	22	135	JISB2401P18
★ C74-08-06N	1/2	3/8	18	12	16.0	11.5	9.0	28	39	22	22	130	JISB2401P14
C74-08-08N	1/2	1/2	18	14	16.0	11.5	11.5	28	39	27	22	140	JISB2401P18
★ C74-08-12N	1/2	3/4	18	17	16.0	11.5	15.5	32	44	32	27	225	JISB2401P24
★ C74-12-08N	3/4	1/2	20	14	21.5	15.5	11.5	32	44	27	27	200	JISB2401P18
C74-12-12N	3/4	3/4	20	17	21.5	15.5	15.5	32	44	32	27	225	JISB2401P24
★ C74-12-16N	3/4	1	20	19	21.5	15.5	21.0	37	47	41	36	250	JISB2401P29
★ C74-16-12N	1	3/4	22	17	27.5	21.0	15.5	37	47	32	36	250	JISB2401P24
C74-16-16N	1	1	22	19	27.5	21.0	21.0	37	49	41	36	300	JISB2401P29

- Material: steel
- Surface finishing: zinc electro-galvanized with color chromating (Ep-Fe/Zn 5/CM2)
- ★ Made-to-order
- ☒ O-ring is not attached.

## Hose couplings: SF, SL, SF45, SF90, AF45, AF90, CF, F

### C79

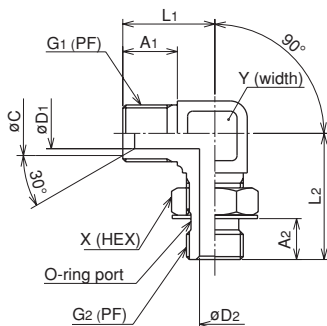

Part No.	G <sub>1</sub>	G <sub>2</sub>	A <sub>1</sub>	A <sub>2</sub>	C	D <sub>1</sub>	D <sub>2</sub>	L <sub>1</sub>	L <sub>2</sub>	X (HEX)	Y (width)	Weight (g)	Suitable O-ring
C79-04-04N	1/4	1/4	14	11	9.5	5.5	5.5	23	32	19	14	60	JISB2401P11
★ C79-04-06N	1/4	3/8	14	12	9.5	5.5	9.0	26	37	22	19	90	JISB2401P14
★ C79-06-04N	3/8	1/4	16	11	13.0	9.0	5.5	29	37	19	19	90	JISB2401P11
C79-06-06N	3/8	3/8	16	12	13.0	9.0	9.0	27	37	22	19	95	JISB2401P14
★ C79-06-08N	3/8	1/2	16	14	13.0	9.0	11.5	29	43	27	22	155	JISB2401P18
★ C79-08-06N	1/2	3/8	18	12	16.0	11.5	9.0	34	43	22	22	155	JISB2401P14
C79-08-08N	1/2	1/2	18	14	16.0	11.5	11.5	34	43	27	22	165	JISB2401P18
★ C79-08-12N	1/2	3/4	18	17	16.0	11.5	15.5	35	49	32	27	265	JISB2401P24
★ C79-12-08N	3/4	1/2	20	14	21.5	15.5	11.5	36	49	27	27	265	JISB2401P18
C79-12-12N	3/4	3/4	20	17	21.5	15.5	15.5	36	49	32	27	270	JISB2401P24
★ C79-12-16N	3/4	1	20	19	21.5	15.5	21.0	40	52	41	36	450	JISB2401P29
★ C79-16-12N	1	3/4	22	17	27.5	21.0	15.5	40	52	32	36	430	JISB2401P24
C79-16-16N	1	1	22	19	27.5	21.0	21.0	40	52	41	36	440	JISB2401P29

- Material: steel
- Surface finishing: zinc electro-galvanized with color chromating (Ep-Fe/Zn 5/CM2)
- ★ Made-to-order
- ☒ O-ring is not attached.

## Hose couplings: SF, SL, SF45, SF90, AF45, AF90, CF, F

## Parallel thread type to equipment side (with 30° male seat)

### D70 type

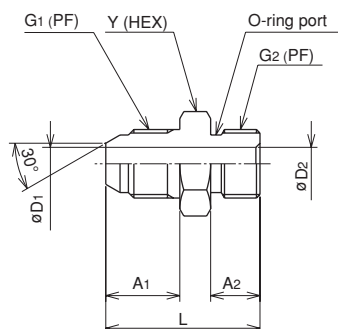

Part No.	G <sub>1</sub>	G <sub>2</sub>	A <sub>1</sub>	A <sub>2</sub>	D <sub>1</sub>	D <sub>2</sub>	L	Y (HEX)	Weight (g)	O-ring
D70-04-04	1/4	1/4	16	12	5.0	5.0	36	19	40	JISB2401P11
★ D70-04-06	1/4	3/8	16	12	5.0	5.0	36	22	50	JISB2401P14
★ D70-06-04	3/8	1/4	18	12	7.0	7.0	38	19	50	JISB2401P11
D70-06-06	3/8	3/8	18	12	8.0	8.0	38	22	55	JISB2401P14
★ D70-06-08	3/8	1/2	18	16	8.0	8.0	44	27	85	JISB2401P18
★ D70-08-06	1/2	3/8	19	12	9.0	9.0	38	27	85	JISB2401P14
D70-08-08	1/2	1/2	20	16	11.0	11.0	46	27	95	JISB2401P18
★ D70-08-12	1/2	3/4	19	16	11.5	11.5	45	32	135	JISB2401P24
★ D70-12-08	3/4	1/2	21	14	11.5	11.5	45	32	135	JISB2401P18
D70-12-12	3/4	3/4	22	17	16.0	16.0	51	36	160	JISB2401P24
★ D70-12-16	3/4	1	22	21	16.0	16.0	55	41	245	JISB2401P29
★ D70-16-12	1	3/4	21	16	15.5	15.5	49	41	245	JISB2401P24
D70-16-16	1	1	21	18	21.0	21.0	51	46	225	JISB2401P29

■ Material: steel

■ Surface finishing: zinc electro-galvanized with color chromating (Ep-Fe/Zn 5/CM2)

★ Made-to-order

☞ O-ring is not attached.

## Hose couplings: SE, SLE, SE45, SE90, AE45, AE90, CE, E

### D74

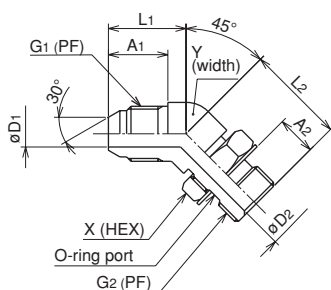

Part No.	G <sub>1</sub>	G <sub>2</sub>	A <sub>1</sub>	A <sub>2</sub>	D <sub>1</sub>	D <sub>2</sub>	L <sub>1</sub>	L <sub>2</sub>	X (HEX)	Y (width)	Weight (g)	O-ring
D74-04-04N	1/4	1/4	16	13	5.0	5.0	21	27	19	17	55	JISB2401P11
★ D74-04-06N	1/4	3/8	16	13	5.0	8.0	24	30	22	19	85	JISB2401P14
★ D74-06-04N	3/8	1/4	17	11	8.0	5.5	25	33	17	19	80	JISB2401P11
D74-06-06N	3/8	3/8	18	13	8.0	8.0	24	30	22	19	80	JISB2401P14
★ D74-06-08N	3/8	1/2	18	16	8.0	11.0	26	35	27	24	135	JISB2401P18
★ D74-08-06N	1/2	3/8	19	12	11.5	8.0	28	39	22	22	130	JISB2401P14
D74-08-08N	1/2	1/2	20	16	11.0	11.0	26	35	27	24	140	JISB2401P18
★ D74-08-12N	1/2	3/4	19	17	11.5	15.5	33	44	32	27	225	JISB2401P24
★ D74-12-08N	3/4	1/2	22	14	15.0	11.5	33	44	27	27	200	JISB2401P18
D74-12-12N	3/4	3/4	22	17	15.5	15.5	33	44	36	27	225	JISB2401P24
★ D74-12-16N	3/4	1	22	17	15.5	21.0	37	47	41	33	250	JISB2401P29
★ D74-16-12N	1	3/4	25	17	21.0	15.0	37	47	32	33	250	JISB2401P24
D74-16-16N	1	1	25	17	21.0	21.0	37	47	41	33	300	JISB2401P29

■ Material: steel

■ Surface finishing: zinc electro-galvanized with color chromating (Ep-Fe/Zn 5/CM2)

★ Made-to-order

☞ O-ring is not attached.

## Hose couplings: SE, SLE, SE45, SE90, AE45, AE90, CE, E

### D79

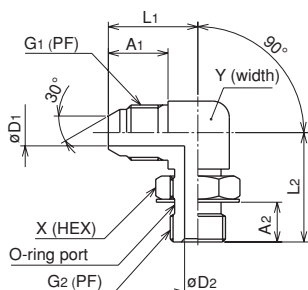

Part No.	G <sub>1</sub>	G <sub>2</sub>	A <sub>1</sub>	A <sub>2</sub>	D <sub>1</sub>	D <sub>2</sub>	L <sub>1</sub>	L <sub>2</sub>	X (HEX)	Y (width)	Weight (g)	O-ring
D79-04-04N	1/4	1/4	16	13	5.0	5.0	25	29	19	17	60	JISB2401P11
★ D79-04-06N	1/4	3/8	16	13	5.0	8.0	26	33	22	19	90	JISB2401P14
★ D79-06-04N	3/8	1/4	18	13	7.0	7.0	29	31	19	19	90	JISB2401P11
D79-06-06N	3/8	3/8	18	13	8.0	8.0	27	33	22	19	95	JISB2401P14
★ D79-06-08N	3/8	1/2	18	16	8.0	11.0	30	40	27	24	165	JISB2401P18
★ D79-08-06N	1/2	3/8	20	12	11.5	8.0	37	43	22	22	165	JISB2401P14
D79-08-08N	1/2	1/2	20	16	11.0	11.0	32	39	27	24	170	JISB2401P18
★ D79-08-12N	1/2	3/4	20	17	11.0	16.0	35	46	36	30	300	JISB2401P24
★ D79-12-08N	3/4	1/2	22	14	15.5	11.5	42	49	27	27	300	JISB2401P18
D79-12-12N	3/4	3/4	22	18	16.0	16.0	37	51	36	30	320	JISB2401P24
★ D79-12-16N	3/4	1	22	17	15.5	21.0	46	52	41	33	470	JISB2401P29
★ D79-16-12N	1	3/4	23	17	21.0	15.0	46	52	32	33	470	JISB2401P24
D79-16-16N	1	1	23	17	21.0	21.0	46	52	41	33	500	JISB2401P29

■ Material: steel

■ Surface finishing: zinc electro-galvanized with color chromating (Ep-Fe/Zn 5/CM2)

★ Made-to-order

☞ O-ring is not attached.

## Hose couplings: SE, SLE, SE45, SE90, AE45, AE90, CE, E

## Taper thread screw type to equipment side (with 30° male seat)

### 010 screw

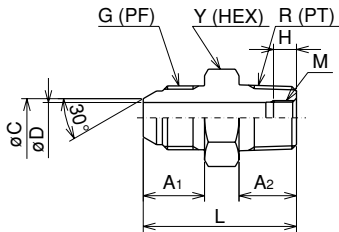

Part No.	G	R	A <sub>1</sub>	A <sub>2</sub>	C	Min. I.D. øD	H	L	M	Y (HEX)	Weight (g)
010-04-04-001	1/4	1/4	14	13	7.5	5.5	6.0	35	M7 x 0.75	19	35
010-06-06-001	3/8	3/8	16	15	10.0	8.0	6.0	40	M9 x 0.75	22	55
★ 010-08-08-001	1/2	1/2	19	18	13.0	11.0	7.5	47	M12 x 1	27	90
★ 010-12-12-001	3/4	3/4	21	20	19.0	16.0	8.5	53	M17 x 1	36	170

- Material: steel
- Surface finishing: zinc electro-galvanized with color chromating (Ep-Fe/Zn 5/CM2)
- ★ Made-to-order

## Hose couplings: SE, SLE, SE45, SE90, AE45, AE90, CE, E

### 090 screw

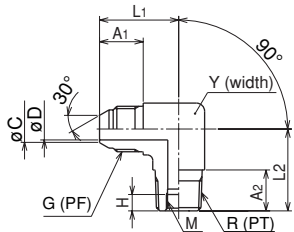

Part No.	G	A <sub>1</sub>	A <sub>2</sub>	C	Min. I.D. øD	H	L <sub>1</sub>	L <sub>2</sub>	Y (width)	M	Weight (g)
090-04-04-001	1/4	14	13	7.5	5	6.0	24	27	17	M7 x 0.75	50
090-06-06-001	3/8	16	15	10.0	8	6.0	29	30	19	M9 x 0.75	90
★ 090-08-08-001	1/2	19	18	13.0	11	7.5	33	38	24	M12 x 1	145
★ 090-12-12-001	3/4	21	20	19.0	16	8.5	36	43	30	M17 x 1	260

- Material: steel
- Surface finishing: zinc electro-galvanized with color chromating (Ep-Fe/Zn 5/CM2)
- ★ Made-to-order

## Hose couplings: SE, SLE, SE45, SE90, AE45, AE90, CE, E

### Bolt for fixed screw adaptor

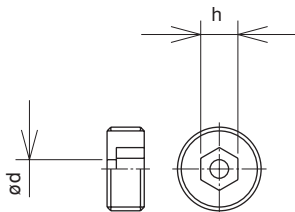

Part No.	Adaptor 1	Adaptor 2	h	ød	Weight (g)
007-04-0.5	010-04-04-001	090-04-04-001	3	0.5	1.0
007-04-0.7	010-04-04-001	090-04-04-001	3	0.7	1.0
007-04-1.0	010-04-04-001	090-04-04-001	3	1.0	1.0
007-04-1.5	010-04-04-001	090-04-04-001	3	1.5	1.0
★ 007-04-2.0	010-04-04-001	090-04-04-001	3	2.0	1.0
★ 007-06-0.5	010-06-06-001	090-06-06-001	4	0.5	1.5
007-06-0.7	010-06-06-001	090-06-06-001	4	0.7	1.5
007-06-1.0	010-06-06-001	090-06-06-001	4	1.0	1.5
★ 007-06-1.5	010-06-06-001	090-06-06-001	4	1.5	1.5
★ 007-08-0.5	010-08-08-001	090-08-08-001	6	0.5	3.0
★ 007-08-0.7	010-08-08-001	090-08-08-001	6	0.7	3.0
★ 007-08-1.0	010-08-08-001	090-08-08-001	6	1.0	3.0
★ 007-08-1.5	010-08-08-001	090-08-08-001	6	1.5	3.0
★ 007-08-2.0	010-08-08-001	090-08-08-001	6	2.0	3.0
★ 007-08-2.5	010-08-08-001	090-08-08-001	6	2.5	3.0
★ 007-12-1.5	010-12-12-001	090-12-12-001	8	1.5	8.0
★ 007-12-2.0	010-12-12-001	090-12-12-001	8	2.0	8.0
★ 007-12-2.5	010-12-12-001	090-12-12-001	8	2.5	8.0
007-12-3.0	010-12-12-001	090-12-12-001	8	3.0	8.0

- Material: brass
- Surface finishing: electroless nickel plated (Ni-P5)
- ★ Made-to-order

## Interconnection type (with 30° male seat)

### 150

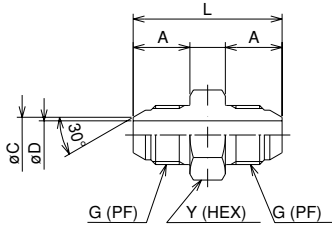

Part No.	G	A	C	Min. I.D. øD	L	Y (HEX)	Weight (g)
150-02-02	1/8	12	4.5	3.0	31	14	15
150-04-04	1/4	14	7.5	5.5	36	19	50
150-06-06	3/8	16	10.0	8.0	42	22	75
150-08-08	1/2	19	13.0	11.0	48	27	85
150-12-12	3/4	21	19.0	16.0	54	36	160
150-16-16	1	23	25.0	22.0	59	41	230

- Material: steel
- Surface finishing: zinc electro-galvanized with color chromating (Ep-Fe/Zn 5/CM2)

## Hose couplings: SE, SLE, SE45, SE90, AE45, AE90, CE, E

### 020 panel touch

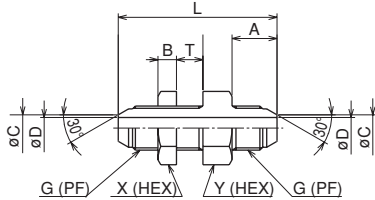

Part No.	G	A	B	C	Min. I.D. øD	L	T (max. panel thickness)	X (HEX)	Y (HEX)	Mounting nut	Weight (g)
020-04-04-001	1/4	14	7.0	7.5	5	54	10	22	22	NP04	75
020-06-06-001	3/8	17	7.0	10.0	8	60	10	24	24	NP06	105
020-08-08-001	1/2	19	10.0	13.0	11	71	10	30	30	NP08	190
★ 020-12-12-001	3/4	21	10.0	19.0	16	79	10	41	41	NP012	365
★ 020-16-16-001	1	23	12.0	25.0	22	87	10	46	46	NP016	505

- Material: steel
- Surface finishing: zinc electro-galvanized with color chromating (Ep-Fe/Zn 5/CM2)
- ★ Made-to-order

## Hose couplings: SE, SLE, SE45, SE90, AE45, AE90, CE, E

### 025 panel touch

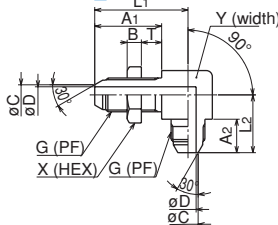

Part No.	G	A <sub>1</sub>	A <sub>2</sub>	B	C	Min. I.D. øD	L <sub>1</sub>	L <sub>2</sub>	T (max. panel thickness)	X (HEX)	Y (width)	Mounting nut	Weight (g)
025-04-04	1/4	32	15	7.0	7.0	5.5	45	26	10	22	22	NP04	125
025-06-06	3/8	33	16	7.0	10.0	8.0	46	29	10	24	24	NP06	160
025-08-08	1/2	40	19	10.0	13.0	11.0	59	35	10	30	30	NP08	320
★ 025-12-12	3/4	41	21	10.0	19.0	16.0	68	42	10	41	41	NP012	685
★ 025-16-16	1	45	23	12.0	25.0	22.0	76	46	10	46	46	NP016	950

- Material: steel
- Surface finishing: zinc electro-galvanized with color chromating (Ep-Fe/Zn 5/CM2)
- ★ Made-to-order

## Hose couplings: SE, SLE, SE45, SE90, AE45, AE90, CE, E

### 064

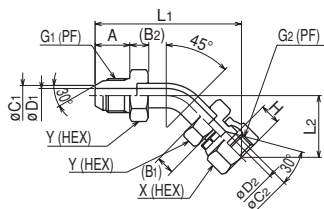

Part No.	G <sub>1</sub>	G <sub>2</sub>	A	B <sub>1</sub>	B <sub>2</sub>	C <sub>1</sub>	C <sub>2</sub>	D <sub>1</sub>	D <sub>2</sub>	H	L <sub>1</sub>	L <sub>2</sub>	X (HEX)	Y (HEX)	Pipe size	Weight (g)
064-04	1/4	1/4	15	8.5	8.5	9.0	9.0	5.0	5.0	8.0	63	26	19	19	ø10 x t2	85
064-06	3/8	3/8	17	9.0	9.0	12.0	12.0	7.0	7.0	9.5	72	30	22	22	ø12 x t2	120
064-08	1/2	1/2	20	9.5	9.5	15.5	15.5	10.0	10.0	12.5	82	32	27	27	ø15 x t2.5	200
064-12	3/4	3/4	21	11.0	10.5	19.0	21.0	16.0	16.0	13.5	95	40	36	36	ø20 x t2.5	350
064-16	1	1	23	12.5	12.5	28.0	28.0	21.5	21.5	16.5	108	47	41	41	ø28 x t3.5	515

- Material: steel
- Surface finishing: zinc electro-galvanized with color chromating (Ep-Fe/Zn 5/CM2)

## Hose couplings: SE, SLE, SE45, SE90, AE45, AE90, CE, E

### 069

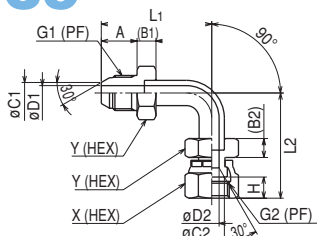

Part No.	G <sub>1</sub>	G <sub>2</sub>	A	B <sub>1</sub>	B <sub>2</sub>	C <sub>1</sub>	C <sub>2</sub>	D <sub>1</sub>	D <sub>2</sub>	H	L <sub>1</sub>	L <sub>2</sub>	X (HEX)	Y (HEX)	Pipe size	Weight (g)
069-04	1/4	1/4	15	8.5	8.5	7.0	9.0	5.0	5.0	8.0	46	45	19	19	ø10 x t2	90
069-06	3/8	3/8	17	9.0	9.0	10.0	12.0	7.0	7.0	9.5	53	50	22	22	ø12 x t2	125
069-08	1/2	1/2	20	9.5	9.5	13.0	15.5	10.0	10.0	12.5	62	55	27	27	ø15 x t2.5	205
069-12	3/4	3/4	21	11.0	10.5	19.0	21.0	16.0	16.0	13.5	74	76	36	36	ø20 x t2.5	375
069-16	1	1	23	12.0	12.5	25.0	28.0	21.5	21.5	16.5	83	87	41	41	ø28 x t3.5	565

- Material: steel
- Surface finishing: zinc electro-galvanized with color chromating (Ep-Fe/Zn 5/CM2)

## Hose couplings: SE, SLE, SE45, SE90, AE45, AE90, CE, E



# Hose Guard Parts and Specially- Treated items

<u>Specially-treated hoses</u>	<u>66</u>
<u>Hose guard parts</u>	<u>67</u>

## Double hoses and triple hoses

Made-to-order



- Two hoses can be adhered together.

### If you use double hoses,

- the piping space can be made compact.
- a single reel pulley suffices.
- hose flopping at pressurization can be minimized.
- ☞ Adhesion of more than three hoses or adhesion with tubes is also possible. Contact us for details.

## Nonconductive (electric insulating) processing

Made-to-order

Although plastic hoses are generally electrically insulated, sometimes leakage current is regulated for hydraulic hoses of electrical work equipment or for the hoses that are especially required to be insulated. When electrical insulation is required, we can make a hose cover with no pin-pricking processing (no pin hole processing for gas venting) in order to prevent the reduction of electrical insulation due to external water invasion.

☞ Contact us for details.

## Outer braid processing

Made-to-order

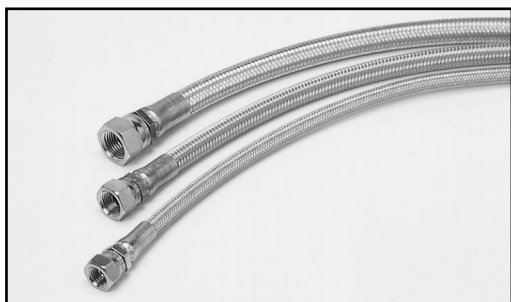

- Processing of steel wire braid and stainless wire braid is possible.

- Guarding hose against powdery metal.
- Maintaining electric conductivity
- Guarding hose against damage

### (Hoses that can be processed)

N3130 series	all sizes
3130 series	all sizes
3000 series	all sizes
3700 series	sizes 03, 04, 06 and 08
N3000 series	sizes 06 and 08
3R80 series	sizes 04, 06, 08 and 12

☞ Contact us for details.

## Colored hose

Made-to-order

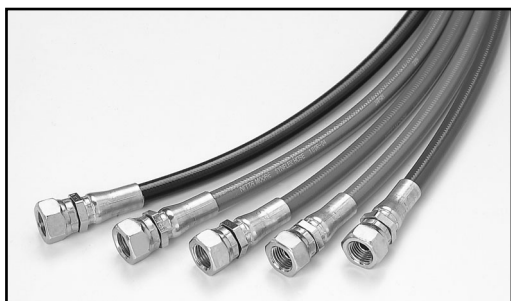

- Hose cover can be colored.

- Coloring hoses (blue, red, gray, green, aqua color, etc)

☞ Contact us for details.

Hydraulic  
Hose

Anti-  
painting  
Hose

Clean  
Hose

Natural-Gas  
Hose

Adaptor

Hose Guard  
Part, Specially-  
Treated Part

Assembling  
Machine,  
Jig, Tool

Hose  
Assembling  
Method

Technical  
Document

Reference  
Document

Hose guard parts attached

① **Covering whole hose**  
G1, S1, E1, P1, C1

② **Covering both ends**  
G2, S2, E2, P2, C2

③ **Covering single end**  
G3, S3, E3, P3, C3

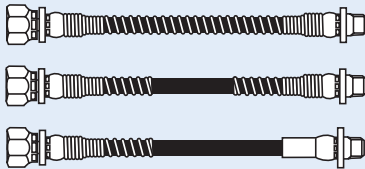

The whole hose is covered.

Both ends of the coupling are covered  
Please specify the length.

One end of the coupling is covered.  
Please specify the length and direction.

☞ For more details, see "How to order hose assembly" on page 6.

## Guard spring



Material: steel (Ep-Fe/Zn 5/CM2)

- ☞ Expand the spring 2-2.5 times the original length when in use
- Attach the spring by screwing over the coupling socket with the hand.
- The spring can also be made of SUS304 or SUS316, please consult us if you need them.

### Features

- It prevents kinks and flattening of the hose.
- It prevents abrasion and damage to the hose.

### Working temperature range

Same as the working temperature range of the hose.

### Part number

G1: For whole hose G2: For both ends G3: For single end

☞ Specify the length for G2 and G3.

### For single part order

☞ Contact us.

Unit length: 1.7 m in contracted state

### For LF70 series

Part No.	Hose size	Spring O.D. (mm)	Spring wire diameter (mm)
YM07-04-1700L-MCH	04	15.3	1.6
YM07-06-1700L-MCH	06	19.1	2.0

### For 1000, 1400, 1500 series

Part No.	Hose size	Spring O.D. (mm)	Spring wire diameter (mm)
YM10-03-1700L-MCH	03	12.9	1.4
YM10-04-1700L-MCH	04	15.8	1.6
YM10-06-1700L-MCH	06	19.6	2.0
YM10-08-1700L-MCH	08	23.0	2.0

### For 1100 series

Part No.	Hose size	Spring O.D. (mm)	Spring wire diameter (mm)
YM11-04-1700L-MCH	04	15.8	1.6
YM11-06-1700L-MCH	06	19.6	2.0
YM11-08-1700L-MCH	08	23.7	2.0

### For N3130, 3130, 3700, 3000, 34PW (04,06,08) series

Part No.	Hose size	Spring O.D. (mm)	Spring wire diameter (mm)
YMS-02-1700L-MCH	02	11.6	1.4
YMS-03-1700L-MCH	03	15.4	1.6
YMS-04-1700L-MCH	04	18.2	2.0
YMS-05-1700L-MCH	05	19.6	2.0
YMS-06-1700L-MCH	06	21.2	2.0
YMS-08-1700L-MCH	08	25.1	2.0
YMS-12-1700L-MCH	12	32.7	2.6
YMS-16-1700L-MCH	16	39.1	2.6

### For N3000, HT series

Part number	Hose size	Spring O.D. (mm)	Spring wire diameter (mm)
YMS-04-1700L-MCH	04	18.2	2.0
YMSN-06-1700L-MCH	06	22.4	2.0
YMSN-08-1700L-MCH	08	26.2	2.0
YMSN-10-1700L-MCH	10	31.7	2.6

### For 3R80, 34PW (12,16) series

Part number	Suitable hose size	Spring outer diameter (mm)	Spring wire diameter (mm)
YMSH-03-1700L-MCH	03	17.3	2.0
YMSH-04-1700L-MCH	04	20.5	2.0
YMSH-06-1700L-MCH	06	23.7	2.0
YMSH-08-1700L-MCH	08	28.1	2.6
YMSH-12-1700L-MCH	12	35.6	2.9
YMSH-16-1700L-MCH	16	43.2	2.9

## Nylon spiral tube

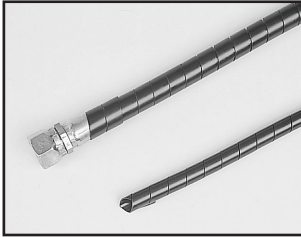

Material: nylon  
 ☞ Polyethylene spiral tube is also available. Contact us for details.  
 Color: black

### Features

- It prevents abrasion and damage to the hose.
- Light
- It can be attached after piping.
- For binding hoses
- Excellent chemical durability

### Working temperature range

(nylon) -40°C to +105°C  
 (polyethylene) -40°C to +85

### Part number

S1: For whole hose S2: For both ends S3: For single end  
 ☞ Specify the length for S2 and S3.

### For single part order

☞ Contact us.

Unit length: SPN-06-0 100M  
 SPN-11-0, SPN-18-0 50M

Part No.	Outer x inner diameters (mm)	Thickness (mm)	Pitch (mm)	Recommended hose size
SPN-06-0-100M	5.5 x 4	0.75	10	02 to 04
SPN-11-0-50M	10.6 x 9	0.8	12	03 to 08
SPN-18-0-50M	16.6 x 15	0.8	18	08 to 16

## Vinyl pipe



Material: vinyl chloride  
 Max attachment length:  
 02 to 06 size: 2.5M  
 08 to 16 size: 1.5M

☞ Contact us for details.

### Features

- For preventing any damage from outside such as stone-hitting etc.

### Working temperature range

0°C to +40°C

### Part number

P1: For whole hose P2: For both ends P3: For single end  
 ☞ Specify the length for P2 and P3.

### For single part order

☞ Contact us.

## Heat contraction tube

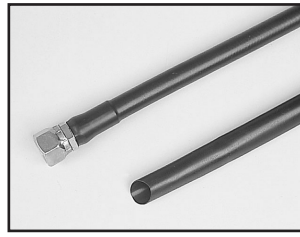

Material: EPR  
 Color: black

### Features

- As an insulator from outside.
- For binding multiple hoses.
- For preventing abrasion and damage to the hose.

### Working temperature range

-50°C to +80°C

### Part number

E1: For whole hose E2: For both ends E3: For single end  
 ☞ Specify the length for E2 and E3.

### For single part order

☞ Contact us.

Unit length: 5M

Part No.	Inner diameter before heat contraction (mm)	Inner diameter after heat contraction (mm)	Thickness after heat contraction (mm)
H990-NT200-5M	20	10.0	1
H990-NT250-5M	25	12.5	1
H990-NT300-5M	30	15.0	1
H990-NT400-5M	40	20.0	1

## Corrugated pipe

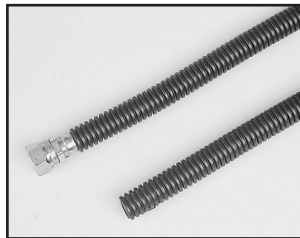

Material: Polypropylene  
 ☞ Nylon corrugated pipe is also available. Contact us for details.

Color: black

### Features

- Light
- Flexible
- It prevents abrasion and damage to the hose.
- The attachment after hose installmet is also possible.

### Working temperature range

-40°C to +95°C

### Part number

C1: For whole hose C2: For both ends C3: For single end  
 ☞ Specify the length for C2 and C3.

### For single part order

☞ Contact us.

# Hose Assembly Machine Special Jigs and Tools

<u>Hose assembly machine</u>	<u>70</u>
<u>Hose assembly special jigs, tools, and equipment</u>	<u>71</u>

Although Nitta Moore plastic hoses and couplings are produced under thorough quality control, they should be correctly assembled to maximize the full potential. Please read the instructions for the use of assembling machines, tools, pushers, and dies, and assemble the hose parts with care. For details, please see the product instruction manual.

## Assembling tool Mark 10

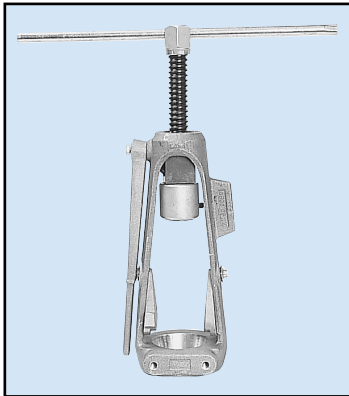

Patent No.888644

Manual tool

### Features

- Light and easy to carry.
- Anywhere, anyplace, for assembling operation

### ■ Specifications

Weight : 4kg

Size : W118 x L118 x H330mm

Material : aluminum die casting

Mark 10 can be used in the following three ways:

- ① Fixed on a vice
- ② Laid on the floor (with rear cushion arm and ratchet wrench HEX32)
- ③ Fixed on a work table by bolts

Assembling method  
P.75

**Caution** Since it is aluminum die casting, strong impact incurred when dropped will cause damage to the body. Please handle with care.

## Assembling machine Mark 9

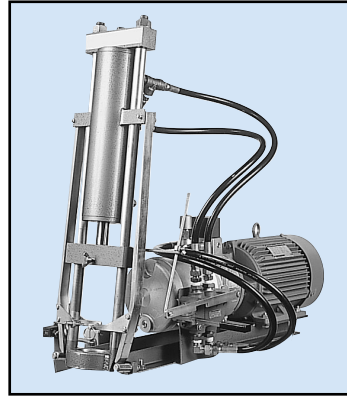

Hydraulic full-automatic machine

### Features

- Significant reduction of the operation time
- Beneficial for assembling a large quantities.

### ■ Specifications

Motor power : 200V, three-phase, 2.2 kw (3 horse power)

Hydraulic pump : Max pressure 14.3 MPa  
Working pressure 11.2 Mpa (relief pressure already set)

Working oil : turbine oil VG46 or the equivalent

Hydraulic cylinder : double-acting special cylinder  
stroke 150 mm

Weight : 90kg

Size : W520 x L820 x H800mm

Assembling method  
P.75



The followings are assembly jigs and tools for Mark 9 and 10.

## Pusher



This is a jig to fix the sleeve of the hose coupling when assembling.

List of suitable part numbers  
P.81

## Die

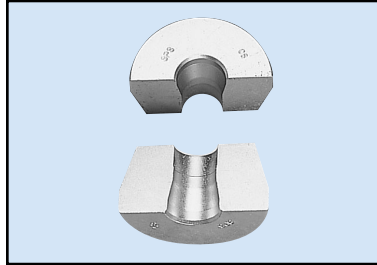

This is a jig to swage the socket of the hose coupling when assembling.

List of suitable part numbers  
P.81

## Hand hose cutter



Part number: HC03  
This can cut hoses from sizes 02 to 08.

## Hose cutter

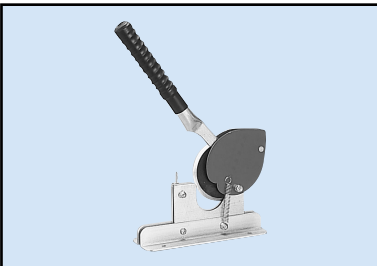

Part number: HC01  
This can cut all hose sizes.  
There are bolt holes in the base to fix the cutter.

## Holding die (vice block)

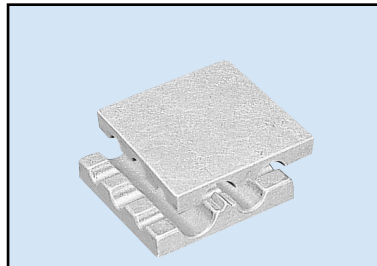

Part number:  
HDD1 (for 03, 04, 05, 06, 08)  
HDD12 (for 08, 12, 16)  
This is used to fix hoses.

## Assembly lubricant



Part number:  
For assembling steel connectors: PG3740 (Nihon Kohsakyu) (lubricant color: green)  
For assembling stainless connectors: CFH68 (Nisseki Mitsubishi) (lubricant color: yellow)  
Content: 500 ml  
This is used when you insert a hose into a hose connector or swage connectors with assembling tools.

## Campucka coupling detachable jig

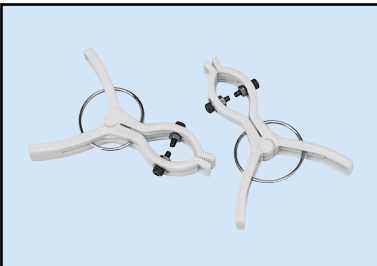

Part number: TRL

## Hose coupling cap seal

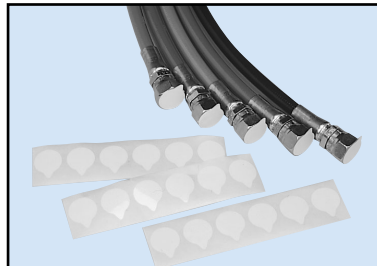

Contact us for details.

### ⚠ Caution

If the recommended lubricant is not applied, coating damage and/or socket buckling may occur.

Hydraulic  
Hose

Airless-  
painting  
Hose

Clean  
Hose

Natural-Gas  
Hose

Adaptor

Hose Guard  
Part, Specially-  
Treated Part

Assembling  
Machine,  
Jig, Tool

Hose  
Assembling  
Method

Technical  
Document

Reference  
Document



# Hose Assembling Methods

<u>Campucka coupling</u>	<b>74</b>
<u>Swage coupling ( with Mark 10)</u>	<b>75</b>
<u>Swage coupling (with Mark 9)</u>	<b>77</b>
<u>Hose assembly document</u>	<b>79</b>
<u>Reusable coupling</u>	<b>81</b>

## Hose Assembling Methods

### 1 Preparation



Prepare appropriate hose, coupling cutter, white pen, torque wrench, seal tape, and detachable jig.

**Caution** If the Campucka is dropped, the nipple part may detach and the hose cannot be inserted. Handle with care.

### 2 Attaching Campucka to equipment



**Type CA**  
Roll seal tape onto the taper thread and connect it to the taper female thread of the equipment with proper torque.

**Type CE**  
Attach an adaptor to the equipment and the Campucka to the adaptor with proper torque.

(proper torque) (N¥m)

Thread size	Taper thread, R thread	Parallel thread, G thread
1/8	10 to 15	15
1/4	25 to 30	25
3/8	45 to 50	34
1/2	60 to 70	59

**Caution** More torque than recommendation may damage the coupling

**Caution** When using a Campucka coupling, mark the hose to check the inserted length, fitting the hose edge to the groove mark of the socket.

**Caution** The Campucka coupling can be used only for specified hoses.

Hose No.	Hose clamp position
3130-02, F3130-02	200mm or more
1000-04, 1400-04, F3130-04	350mm or more
1000-06, 1400-06, F3130-06	400mm or more
1000-08, F3130-08	500mm or more

### 3 Hose cutting



Use the specified hose cutter to cut the hose squarely

**Caution** The slanted cut section may cause pullout of the hose and leakage.

**Caution** If the blade is blunt, the hose cut section becomes elliptic, causing pullout of the nipple O-ring on insertion and leakage. Change the cutter in this case.

**Caution** Do not touch the blade of the cutter.

### 4 Marking the insertion length of the hose

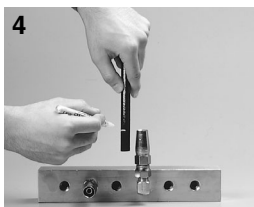

As shown in the figure, mark the hose with a white pen, fitting the hose edge to the groove mark of the socket.

### 5 Inserting the hose to the Campucka

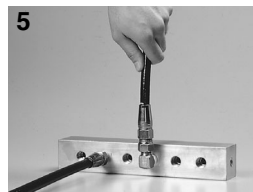

Insert the hose into the coupling until it meets the marked position. Repeat the same steps 2-5 for the other end of the Campucka.

**Warning** If the insertion is insufficient, pullout of the hose or leakage may occur.

**Caution** If the hose is inserted in a tilted position, the inner part (gripper) may be deformed, interfering with the insertion.

### 6 Completing hose assembling



Pressurization swages the hose with an appropriate force according to the pressure.

(hose displacement by the pressurization) 1000, 1400 series

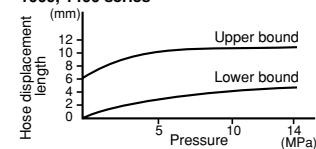

F3130-04/06/08

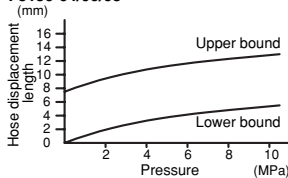

3130-02, F3130-02

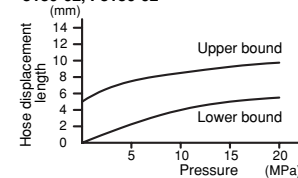

**Warning** Since displacement by the pressurization makes the hose longer, check for interference with the equipment and kinks in the hose.

### 7 Detaching hose (1)

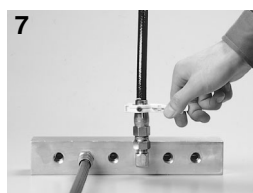

Detaching method ( detachable only before pressurization) Insert the (two) edge pins of the detachable jig into the side holes of the socket.

### 8 Detaching hose (2)

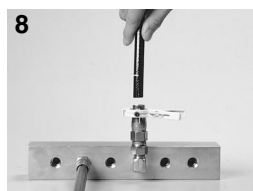

Push the hose toward the Campucka and then slowly pull it out.

**Caution** The hose cannot be pulled out after pressurization. If it is forced, the inner part of the coupling could be damaged, causing pullout of the hose or leakage.

**Caution** The hose and the Campucka are not reusable once pressurized.

## Setup and specifications

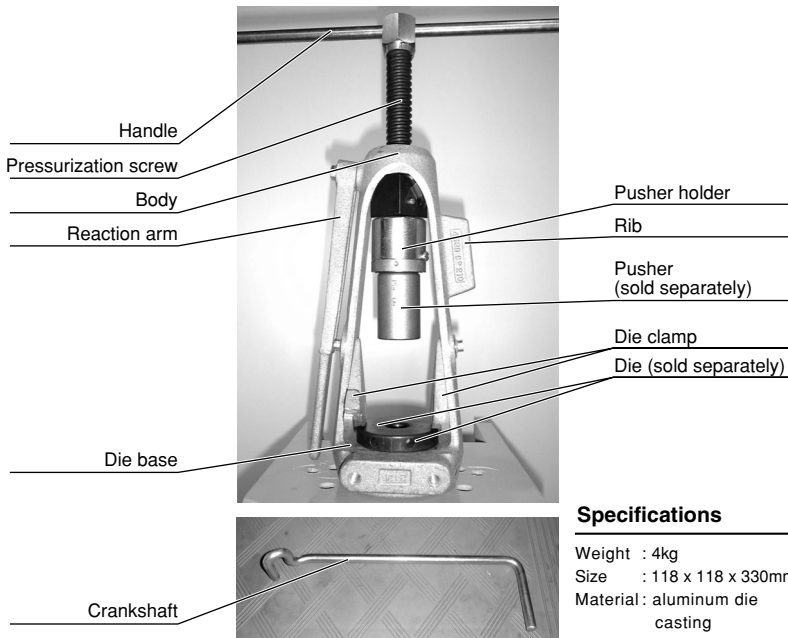

### Specifications

Weight : 4kg  
 Size : 118 x 118 x 330mm  
 Material: aluminum die casting

There are three ways to set Mark 10 as follows:

### 1 Fixed on vice (recommended)

Fix the rib of Mark 10 with a vice.  
 (In this document, we follow this way of setting.)

### 2 Laid on floor

Lay Mark 10 with the support of the reaction arm.

### 3 Fixed on the working base

Use the optional fixing bracket and fix the bracket onto the working base with bolts.

## Assembling method

### 1 Preparation



Prepare appropriate hose, swage coupling, pusher, die, hose cutter, holding die, lubricant\*, plastic hammer, scale, and white pen.

\*lubricant...Steel connector : Nihon Kosakuyu PG3740  
 Stainless connector : Nisseki Mitsubishi CFH68

A 50cc bottle of lubricant (for steel coupling) comes with a set.

**Caution** If the recommended lubricant is not applied, coating damage and/or socket buckling may occur

### 2 Hose cutting



Determine the cutting length of the hose based on the hose assembling length and cut the hose squarely using the special hose cutter.

- Caution** Do not touch the blade of the cutter.
- Caution** The slanted cut section could cause pullout of the hose and leakage.
- Caution** If the blade is blunt, correct assembly is not possible. Change the hose cutter in this case.

### 3 Marking the insertion length of the hose



Measure the insertion length of the hose with a scale and mark the hose at the insertion length with the white pen.

It is recommended to draw a marking line with a width of about 2 mm in order to check it after swaging.

### 4 Preparation for the hose insertion

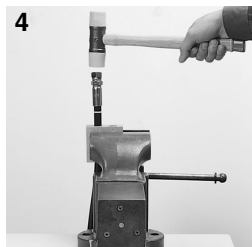

Apply the lubricant to the inner surface of the hose and insert the coupling to the marked position. When it is difficult, use the holding die to fix the hose and hit the coupling with the plastic hammer.

**Caution** If the insertion is incomplete, pullout of the hose, leakage, or damage may occur.

### 5 Fixing Mark 10



Fix the rib of Mark 10 on the vice and pull out the pressurization screw to the longest position. The die clamp should be open as shown in the figure.

**Caution** If you release your grip, the pusher holder will come down by its own weight. Take care not to trap your fingers.

### 6 Attachment of pusher



Attach the pusher to the pusher holder. Fix the pusher by turning the screw of the pusher holder with the hand so that the pusher can freely rotate. Check if the pusher is really able to rotate.

**Caution** The wrong choice of pusher will cause pullout of the hose, leakage, or damage.

## 7 Application of lubricant

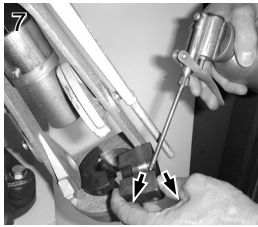

Apply lubricant to the inner surface of the die.

\*lubricant ...Steel coupling : Nihon Kosakuyu PG3740 or equivalent

Stainless coupling: Nisseki Mitsubishi CFH68 or equivalent

**Caution** If the recommended lubricant is not applied, coating damage and/or socket buckling may occur.

## 8 Fixing a mate of the die



Fix a mate of the die onto the tapered base.

**Caution** The wrong choice of pusher will cause pullout of the hose, leakage, or damage.

## 9 Insertion to pusher



Insert the coupling, to which the hose is inserted, into the pusher.

## 10 Fixing the other mate of the die



Put the other mate of the die on the base. Turn the die clamp to lock the die and fix it firmly.

**Warning** Do not put your hand in the die.

## 11 Adjustment of positions of die and coupling



Hold the hose beneath the die base with your left hand. Pushing the coupling toward the pusher, turn the pressurization screw clockwise with your right hand to send the pusher down. As the pusher comes down, adjust the positions of the die hole and the coupling edge so they coincide.

**Caution** Discrepancy of the positions of the die hole and the coupling edge might cause damage to the coupling, such as socket defect.

## 12 Rotating handle



12 Do not over-tighten the screw.

Attach the handle to the pressurization screw and rotate the handle clockwise to send the pusher down. Continue until the pusher touches the die.

**Caution** If you stop before the pusher touches the die, the swaging is insufficient and pullout of the hose or leakage may occur.

**Caution** If you do not stop rotating the handle even after the pusher reaches the die, the tool may crash.

**Caution** Do not take your hands off the handle abruptly. The handle will return in a dangerous fashion.

**Caution** For safe operation, do not get your hands trapped.

## 13 Detaching hose assembly

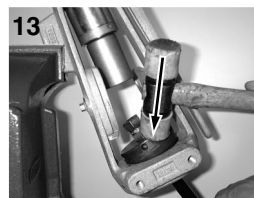

13

Un-install the die clamp, rotate the pressurization screw anti-clockwise to send the pusher up, and remove the hose assembly from the die. If it is difficult to remove the assembly, gently tap the die with the plastic hammer.

**Warning** Pay strict attention to prevent the die from falling.

## 14 Completion of hose assembling



14

**Caution** Before putting the die in storage, remove dust from the inner surface and thinly grease it to prevent rust.

## 15 Check of hose assembly

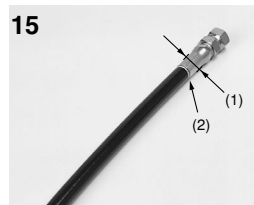

15

- (1) Check the swage diameter (see p.81).
- (2) Check the mark position of the hose insertion length.
- (3) Check the appearance of the coupling. (Check for any damage or misalignment of the track of the die.)
- (4) Check the appearance of the hose. (Check for any kink or cut.)

Should problems occur, do not use the hose assembly.

 For details such as maintenance, please read the instruction manual that comes with the product.



## Setup and specifications

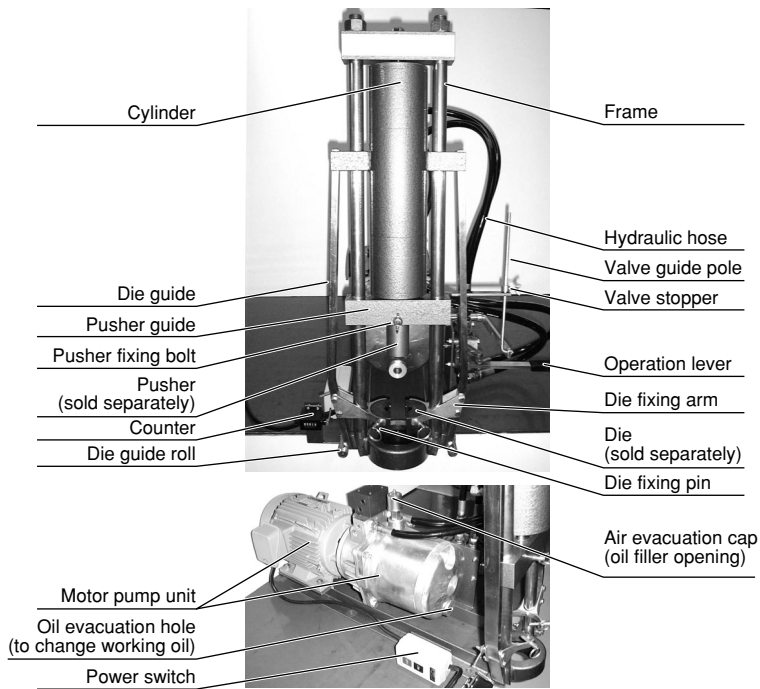

### Specifications

Weight	: 90kg
Size	: 520x820x800mm
Electric motor	: three phase 200V 2.2kw
Hydraulic pump	: Max. pressure 14.3 MPa Working pressure 11.2 MPa (Relief pressure already set)
Hydraulic cylinder	: Double-acting special cylinder stroke 150 mm
Working oil	: turbine oil VG46 or equivalent

For details such as setting-up and electric wiring, please read the instruction manual that comes with the product.

## Assembling method

### 1 Preparation



Prepare appropriate hose, swage connector, pusher, die, hose cutter, holding die, lubricant\*, plastic hammer, scale, and white pen.

\*lubricant...Steel coupling : Nihon Kosakuyu PG3740 or equivalent  
Stainless coupling: Nisseki Mitsubishi CFH68 or equivalent

A 50cc bottle of lubricant (for steel coupling) comes with a set.

**Caution** If the recommended lubricant is not applied, coating damage and/or socket buckling may occur.

### 2 Hose cutting



Determine the cutting length of the hose based on the hose assembling length and cut the hose squarely using the specific hose cutter

**Caution** Do not touch the blade of the cutter.  
**Caution** The slanted cut section could cause pullout of the hose and leakage.  
**Caution** If the blade is blunt, correct assembly is not possible. Change the hose cutter in this case.

### 3 Marking the insertion length of the hose



Measure the insertion length of the hose with the scale and mark the position on the hose with the white pen.

It is recommended to draw a marking line of a width of about 2 mm in order to check it after the swaging.

### 4 Preparation for the hose insertion

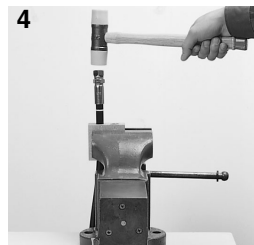

Apply the lubricant to the inner surface of the hose and insert the coupling to the marked position. When it is difficult, use the holding die to fix the hose and hit the coupling with the plastic hammer.

**Caution** If the insertion is insufficient, pullout of the hose, leakage, or damage may occur.

### 5 Lifting pusher holder



Push the operation lever to the back to lift up the pusher holder.

**Warning** Do not let the pusher holder down before the die pusher is attached.

### 6 Attachment of pusher



Attach the pusher to the pusher holder. Fix the pusher by turning the screw of the pusher holder so that the pusher can freely rotate.

**Warning** Only operate with the power off.

**Caution** The wrong choice of pusher will cause pullout of the hose, leakage, or damage.

## 7 Fixing die



Attach the die onto the die fixing arm using the fixing pin.

**Warning** Only operate with the power off.

**Caution** The wrong choice of pusher will cause pullout of the hose, leakage, or damage.

## 8 Application of lubricant



Apply lubricant to the inner surface of the die.

\*lubricant ...Steel coupling : Nihon Kosakuyu  
PG3740 or equivalent  
stainless coupling: Nisseki Mitsubishi  
CFH68 or equivalent

**Caution** If the recommended lubricant is not applied, coating damage and/or socket buckling may occur.

## 9 Insertion to pusher



Insert the coupling, to which the hose is inserted, into the pusher.

**Warning** Use a hose of sufficient length to hold the hose.

## 10 Hose assembling (1)

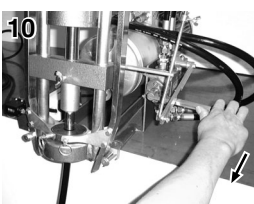

Hold the hose beneath the die base with your left hand. Pushing the connector toward the pusher, pull the operation lever with your right hand to send the pusher down.

As the pusher comes down, adjust the positions of the die hole and the connector edge so they coincide.

- Danger** It is dangerous to hold the hose near the die base. The die could trap your hand.
- Danger** Never touch the moving parts when operating the tool.
- Caution** Discrepancy of the positions of the die hole and the connector edge might cause damage to the coupling, such as socket defect.
- Caution** When the die closes, check that the hose is not stuck in the die.

## 11 Hose assembling (2)

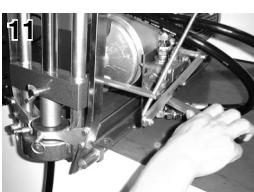

Pull the operation lever until the pusher touches the die.

**Caution** If you stop before the pusher touches the die, the swaging is insufficient and pullout of the hose or leakage may occur.

## 12 Hose assembling 930

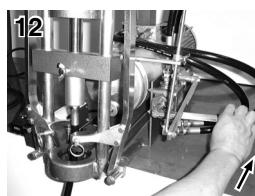

Push the operation lever to the back with your right hand to send the pusher up. When the pusher goes up, the die opens by itself and the hose assembly can be removed.  
(The valve stopper adjusts the upper position of the cylinder.)

## 13 Completion of hose assembling

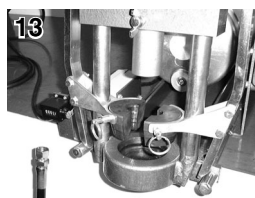

**Caution** Before putting the die in storage, remove dust from the inner surface and thinly grease it to prevent rust.

## 14 Check of hose assembly

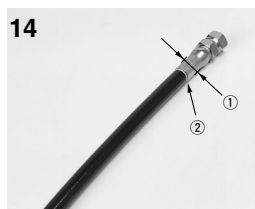

- (1) Check the swage diameter (see p.81).
- (2) Check the mark position of the hose insertion length.
- (3) Check the appearance of the coupling. (Check for any damage or misalignment of the track of the die.)
- (4) Check the appearance of the hose. (Check for any kink or cut.)

Should problems occur, do not use the hose assembly.

 For details such as notes on operation, fine adjustment of each part, repair and maintenance, please read the instruction manual that comes with the product.

## [Swage coupling] \* For any couplings which are not introduced in the catalogue, please contact us.

### A Coupling deduction length

The cutting length of a hose is obtained by the hose-coupling assembly length minus the coupling deduction length\*.

\* Coupling deduction length: A (SA coupling) and B (SE, SF coupling) in the figure.

Ex. 3130-08 x 1000L SA-PT-08 x SE-PF-08  
If you wish to make a hose assembly using the above, cut the hose at the length of  $1000 - (39 + 44) = 917$ .

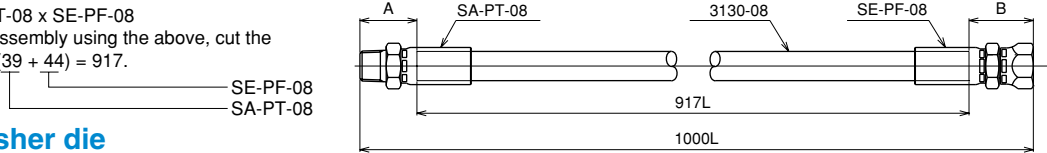

### B Selection of pusher die

Part numbers are punched on pushers and dies.

The wrong pusher or die will cause oil leakage or pullout of the hose, or disable hose assembling, so always check the number.

### C Hose insertion length

Hose insertion lengths are presented in the list below.

A shortage of hose insertion length will cause oil leakage or pullout of the hose. So mark the hose at the hose insertion length given in the list and insert the coupling into the hose to meet the marked position.

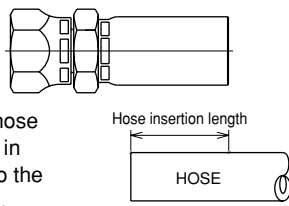

### D Socket outer diameter after swaging

The socket outer diameter after swaging is measured at the point of about 10 mm from the socket end. Please regularly check the finished size. If the size is not appropriate, consult us to avoid possible oil leakage or pullout of the hose.

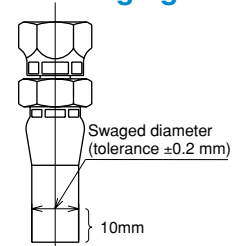

Measure diameter in two square directions

### Steel coupling

Hose series	Hose size	Swage coupling part No.	A		B		C	D
			Coupling deduction length (mm)	Pusher part No.	Die part No.	Hose insertion length (mm)		
LF70	04	SA-R-04-07	28.0	PSA-04	SP07-04	14	12.4 *1	
		SE-G-04-07	27.0	PSE-14-04				
		SF-G-04-07	27.0	PSE-14-04				
	06	SA-R-06-07	30.0	PSA-06	SP07-06	19	15.6 *1	
		SE-G-06-07	29.0	PSE-14-06				
		SF-G-06-07	29.0	PSE-14-06				
1000/1100/1400	04	SA-PT-04-14	32.0	PSA-04	SP14-04	19	12.7	
		SE-PF-04-14	31.0	PSE-14-04				
		SF-PF-04-14	31.0	PSE-14-04				
	06	SA-PT-06-14	33.0	PSA-06	SP14-06	22	15.9	
		SE-PF-06-14	32.0	PSE-14-06				
		SF-PF-06-14	32.0	PSE-14-06				
1000	08	SA-PT-08-14	37.0	PSA-08	SP14-08	24	19.5	
		SE-PF-08-14	37.0	PSE-14-08				
		SF-PF-08-14	37.0	PSE-14-08				
1100	08	SA-PT-08-14	37.0	PSA-08	SP10-08	24	19.9	
		SE-PF-08-14	37.0	PSE-14-08				
		SF-PF-08-14	37.0	PSE-14-08				
1500	03	SA-PT-03-14	30.0	PSA-04	SP14-03	14.5	10.5	
		SE-PF-03-14	29.0	PSE-14-04				
		SF-PF-03-14	29.0	PSE-14-04				
3130/34PW	02	SSA-PT-02	26.0	PSA-02	SP3-02-001	12	9.2	
		SSE-PF-02	30.0	PSE-02-001				
		SSF-PF-02	30.0	PSE-02-001				
N3130/3700 3130/3000 34PW	03	SA-PT-03	32.0	PSA-04	SP3-03	26	12.4	
		SE-PF-03	33.0	PSE-03				
		SF-PF-03	33.0	PSE-03				
	04	SA-PT-04	33.0	PSA-04	SP3-04	28	14.4	
		SE-PF-04	36.0	PSE-04				
		SF-PF-04	36.0	PSE-04				
	05	SA-PT-05	35.0	PSA-06	SP3-05	28	16.0	
		SE-PF-05	38.0	PSE-05				
		SF-PF-05	38.0	PSE-05				
	06	SA-PT-06	35.0	PSA-06	SP3-06	33	17.6	
		SE-PF-06	39.0	PSE-06				
		SF-PF-06	39.0	PSE-06				
08	SA-PT-08	39.0	PSA-08	SP3-08	37	21.5		
	SE-PF-08	44.0	PSE-08					
	SF-PF-08	44.0	PSE-08					
N3130/3700 3130/3000	12	SA-PT-12	43.0	PSA-12	SP3-12	40	28.1	
		SE-PF-12	47.0	PSE-12				
		SF-PF-12	47.0	PSE-12				
	16	SA-PT-16	48.0	PSA-16	SP3-16	52	34.5	
		SE-PF-16	53.0	PSE-16				
		SF-PF-16	53.0	PSE-16				
N3000/HT	04	SA-PT-04	33.0	PSA-04	SPN-04	28	14.6	
		SE-PF-04	36.0	PSE-04				
		SF-PF-04	36.0	PSE-04				
	06	SA-PT-06-N30	35.0	PSA-06	SPN-06	33	18.9	
		SE-PF-06-N30	39.0	PSE-06				
		SF-PF-06-N30	39.0	PSE-06				
08	SA-PT-08-N30	39.0	PSA-08	SPN-08	37	22.7		
	SE-PF-08-N30	44.0	PSE-08					
	SF-PF-08-N30	44.0	PSE-08					

Hose series	Hose size	Swage coupling part No.	A	B		C	D
			Coupling deduction length (mm)	Pusher part No.	Die part No.	Hose insertion length (mm)	Socket outer diameter after swaging (mm) $\pm 0.2$
N3000/HT	10	SA-PT-10-N30	40.0	PSA-10	SPN-10	40	26.2
		SE-PF-10-N30	44.0	PSE-10			
		SF-PF-10-N30					
3R80	03	SA-PT-03-3R	35.0	PSA-04	SPH-03	23	13.5
		SE-PF-03-3R	36.0	PSE-03			
		SF-PF-03-3R					
	04	SA-PT-04-3R	33.0	PSA-04	SPH-04	28	17.2
		SE-PF-04-3R	36.0	PSE-04			
	06	SA-PT-06-N30	35.0	PSA-06	SPH-06	33	20.1
		SE-PF-06-N30	39.0	PSE-06			
	08	SA-PT-08-N30	39.0	PSA-08	SPH-08	37	23.0
SE-PF-08-N30		44.0	PSE-08				
3R80/34PW	12	SA-PT-12-3R	43.0	PSA-12	SPH-12	40	29.5
		SE-PF-12-3R	47.0	PSE-12			
		SF-PF-12-3R					
	16	SA-PT-16-3R	48.0	PSA-16	SPH-16	52	37.8
		SE-PF-16-3R	53.0	PSE-16			

\*1 The tolerance of the socket outer diameter after swaging for LF70 is  $\pm 0.1$ mm.

## Stainless coupling

Hose series	Hose size	Swage coupling part No.	A	Pusher part No.	B		C	D
			Coupling deduction length (mm)		Die part No.			
					First	Second		
1000/1100/1400	04	SA-PT-04-14-S	32.0	PSA-04	SPH-03	SP14-04	19	12.7
		SE-PF-04-14-S	31.0	PSE-14-04				
		SF-PF-04-14-S						
1000	06	SA-PT-06-14-S	33.0	PSA-06	SP3-05-1-ST	SP14-06	22	15.9
		SE-PF-06-14-S	32.0	PSE-14-06				
		SF-PF-06-14-S						
1000	08	SA-PT-08-14-S	37.0	PSA-08	SPH-06-1-ST	SP14-08	24	19.5
		SE-PF-08-14-S	37.0	PSE-14-08				
		SF-PF-08-14-S						
1100	08	SA-PT-08-14-S	37.0	PSA-08	SPH-06-1-ST	SP10-08	24	19.9
		SE-PF-08-14-S	37.0	PSE-14-08				
		SF-PF-08-14-S						
3130/34PW	02	SSA-PT-02-S	26.0	PSA-02	SP3-02-001	-	12	9.2
		SSE-PF-02-S	30.0	PSE-02-001				
		SSF-PF-02-S						
N3130/3700 3130/3000	03	SA-PT-03-S	32.0	PSA-04	SP3-03-1-ST	SP3-03	24	12.4
		SE-PF-03-S	33.0	PSE-03				
N3130/3700	04	SA-PT-04-S	33.0	PSA-04	SP3-04-1-ST	KM-04	28	14.0 <sup>2</sup>
		SE-PF-04-S	36.0	PSE-04				
3130/3000 34PW	04	SA-PT-04-S	33.0	PSA-04	SP3-04-1-ST	SP3-04	28	14.4
		SE-PF-04-S	36.0	PSE-04				
N3130/3700 3130/3000	06	SA-PT-06-S	35.0	PSA-06	SP3-06-1-ST	SP3-06	33	17.6
		SE-PF-06-S	39.0	PSE-06				
		SF-PF-06-S						
	08	SA-PT-08-S	39.0	PSA-08	SP3-08-1-ST	SP3-08	37	21.5
		SE-PF-08-S	44.0	PSE-08				
	12	SA-PT-12-S	43.0	PSA-12	SP3-12-1-ST	SP3-12	40	28.1
		SE-PF-12-S	47.0	PSE-12				
		SF-PF-12-S						
16	SA-PT-16-S	48.0	PSA-16	SP3-16-1-ST	SP3-16	52	34.5	
	SE-PF-16-S	53.0	PSE-16					
N3000/HT	04	SA-PT-04-S	33.0	PSA-04	SPH-04-1-ST	SPN-04	28	14.6
		SE-PF-04-S	35.0	PSE-04				
	06	SA-PT-06-N30-S	34.0	PSA-06	SPH-06-1-ST	SPN-06	33	18.9
		SE-PF-06-N30-S	38.0	PSE-06				
	08	SA-PT-08-N30-S	39.0	PSA-08	SPH-08-1-ST	SPN-08	37	22.7
SE-PF-08-N30-S		43.0	PSE-08					
3R80	04	SA-PT-04-3R-S	33.0	PSA-04	SPH-04-1-ST	SPH-04	28	17.2
		SE-PF-04-3R-S	35.0	PSE-04				
	06	SA-PT-06-N30-S	34.0	PSA-06	SPH-06-1-ST	SPH-06	33	20.1
		SE-PF-06-N30-S	38.0	PSE-06				
08	SA-PT-08-N30-S	39.0	PSA-08	SPH-08-1-ST	SPH-08	37	23.0	
	SE-PF-08-N30-S	43.0	PSE-08					
3R80/34N	12	SE-PF-12-3R-S	47.0	PSE-12	SPH-12-1-ST	SPH-12	40	29.5
	16	SE-PF-16-3R-S	53.0	PSE-16	SPH-16-1-ST	SPH-16	52	37.8
34PW	04	SE-G-04-PW	36.0	PSE-04	SP3-04-VC	-	28	14.4
	06	SE-G-06-PW	39.0	PSE-06	SP3-06-VC	-	33	17.6
	08	SE-G-08-PW	44.0	PSE-08	SP3-08-VC	-	37	21.5
	12	SE-G-12-PW	47.0	PSE-12	SPH-12-1-ST	SPH-12-VC	40	29.5
	16	SE-G-16-PW	53.0	PSE-16	SPH-16-1-ST	SPH-16-37VC	52	37.0
	04	SE-G-04-PWL	31.0	PSE-04-PWL	SPP-04-VC	-	11	14.7
	06	SE-G-06-PWL	32.0	PSE-06-PWL	SPP-06-VC	-	11	18.0
	08	SE-G-08-PWL	39.0	PSE-08-PWL	SPP-08-VC	-	14	21.8
	12	SE-G-12-PWL	42.0	PSE-12-PWL	SPP-12-VC	-	21	29.6
	16	SE-G-16-PWL	45.0	PSE-16-PWL	SPP-16-VC	-	29	37.2

\*2 Use KM-04 for N3130 and 3700.



## Assembling method

### 1 Preparation



Prepare appropriate hose, coupling, hose cutter, holding die, lubricant\*, adjustable wrench, scale, and white pen.

\*lubricant...Steel coupling : Nihon Kosakuyu PG3740 or equivalent  
Stainless coupling : Nisseki Mitsubishi CFH68 or equivalent

**Caution** If the recommended lubricant is not applied, coating damage and /or socket buckling may occur.

### 2 Hose cutting



Determine the cutting length of the hose based on the hose assembling length and cut the hose squarely using the special hose cutter.

**Caution** Do not touch the blade of the cutter.  
**Caution** The slanted cut section could cause pullout of the hose and leakage.  
**Caution** If the blade is blunt, correct assembly is not possible. Change the hose cutter in this case.

### 3 Marking the insertion length of the hose



Measure the insertion length of the hose with the scale and mark the position on the hose with the white pen.

It is recommended to draw a marking line of a width of about 2 mm in order to check it after the swaging.

### 4 Disassembling of coupling

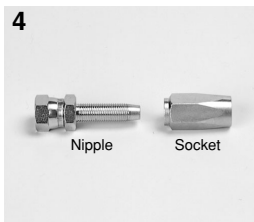

Disassemble the reusable coupling into socket and nipple.

### 5 Preparation to insert coupling



Nip the hose with the holding die, leaving the length of hose end to be inserted into the socket, and fix it in the vice. For easy screwing, apply lubricant to the surface of the hose end.

### 6 Insertion of socket

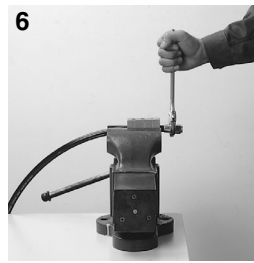

Insert the socket into the hose end and tighten it anti-clockwise with your hand. Then use the adjustable wrench to screw the socket to the position marked on the hose. Check that there is about a 2-3 mm space between the inner end of the socket and the hose end.

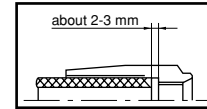

**Caution** Stop screwing before the inner end of the socket reaches the hose end, otherwise damage to the core tube will occur and cause leakage.

### 7 Insertion of the nipple (1)



Remove the assembly from the vice and the holding die. Nip the socket with the vice and apply lubricant to the nipple thread and the inner surface of the hose.

### 8 Insertion of the nipple (2)



Tighten the nipple clockwise with your hand and use an appropriate adjustable wrench to slowly screw the nipple until its hexagonal part touches the socket.

**Caution** Do not screw further, once the nipple touches the socket. It may cause damage to the coupling.  
**Caution** Using a machine to quickly screw the nipple may cause damage to the core tube or the coupling, leading to pullout of the hose or leakage.

### 9 Completion of hose assembling



After finishing the tightening of the nipples, check for deformation of the core tube by inserting a checking stick into the coupling.

### 10 Check of hose assembly



(1) Check the mark position of the hose insertion length.  
(2) Check the appearance of the coupling. (Check for any damage.)  
(3) Check the appearance of the hose. (Check for any kink or cut.)  
Should problems occur, do not use the hose assembly.

For details such as repair and maintenance, please read the instruction manual that comes with the product.

**[Reusable coupling]** \* For any couplings which are not introduced in the catalogue, please contact us.

### A Coupling deduction length

The cutting length of a hose is obtained by the hose-coupling assembly length minus the coupling deduction length\*.

\* Coupling deduction length: A (SA coupling) and B (SE, SF coupling) in the figure.

Ex. 3130-08 x 1000L SA-PT-08 x E-PF-08  
If you wish to make a hose assembly using  
the above, cut the hose at the length of  
 $1000 - (43 + 46) = 911$ .

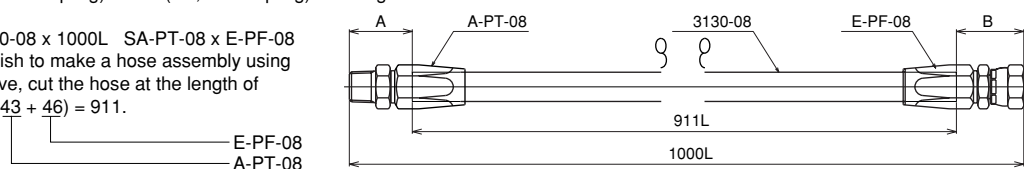

### B Hose insertion length

Hose insertion lengths are presented in the list below.

A shortage of hose insertion length will cause oil leakage or pullout of the hose. So mark the hose at the hose insertion length given in the list and insert the coupling into the hose to meet the marked position.

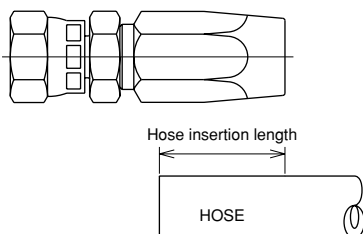

Table of hose screwing length

Hose series	Hose size	Reusable coupling part No.	A	B
			Coupling deduction length (mm)	Hose insertion length (mm)
3130	02	A-PT-02	25.5	16
		E-PF-02	31.5	
		F-PF-02	31.5	
3130-3000	03	A-PT-03	30.0	21
		E-PF-03	32.5	
		F-PF-03	32.5	
3130	04	A-PT-04	31.5	25
		E-PF-04	34.0	
		F-PF-04	34.0	
3130	05	A-PT-05	35.5	29
		E-PF-05	37.0	
		F-PF-05	37.0	
3130-3000	06	A-PT-06	37.5	30
		E-PF-06	40.0	
		F-PF-06	40.0	
	08	A-PT-08	43.0	36
		E-PF-08	46.0	
		F-PF-08	46.0	
3000	12	A-PT-12	46.5	38
		E-PF-12	47.5	
		F-PF-12	47.5	
3000	16	A-PT-16	49.5	42
		E-PF-16	50.0	
		F-PF-16	50.0	

# Technical Document

<b><u>How to select a hose</u></b>	<b>84</b>
<b><u>How to determine the hose length</u></b>	<b>86</b>
<b><u>How to select the hose size for given flow volume and velocity</u></b>	<b>87</b>
<b><u>Graphs for cubical expansion of hoses</u></b>	<b>88</b>
<b><u>Tightening torque for hose couplings and adapters</u></b>	<b>89</b>

## How to read the catalog

### N3130

#### Features

- Flexible and tough
- JIS K 6375 type 1 certificated, SAE100R7 certificated
- Nonconductive hose with high electrical insulation is also available.

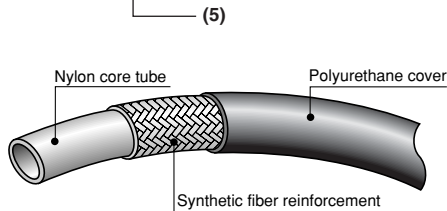

Part No.	(1) Size			(2)			(3)		(4)	
	Size No.	Inner diameter (in.)	Inner diameter (mm)	Outer diameter (mm)	Maximum working pressure (MPa)	Maximum impact pressure (MPa)	Minimum destruction pressure (MPa)	Minimum bending radius (mm)	Weight (g/m)	Suitable coupling
N3130-03	03	3/16	4.8	10.4	21.0	26.3	84.0	20	65	Swage
N3130-04	04	1/4	6.4	12.7	19.5	24.4	77.0	40	105	
N3130-05	05	5/16	8.1	14.7	17.5	21.9	70.0	45	130	
N3130-06	06	3/8	9.8	16.4	16.0	20.0	63.0	50	150	
N3130-08	08	1/2	12.8	20.3	14.0	17.5	56.0	75	210	
N3130-12	12	3/4	19.2	26.6	9.0	11.3	35.0	130	290	
N3130-16	16	1	25.7	33.4	7.0	8.8	28.0	165	400	

- Appropriate fluid: mineral hydraulic oil
- Working temperature range: -40 to +100°C
- Unit length in a package: 100 m for sizes 03, 04, 05, 06, 08, and 50 m for sizes 12, 16

### (1) Size (inner diameter)

It is necessary to select the correct hose size (inner diameter) to obtain the necessary flow volume.

In general, the flow speed range shown below is the standard.

Too small an inner diameter of hose and coupling leads to an increase of flow speed, which causes problems such as pressure loss and increase of oil temperature. Pressure loss may vary with fluid viscosity, flow volume, and circuit length.

To see how flow speed, inner diameter, and flow volume, relate to each other, refer to [nomograph] on P.87

<b>Pump intake and return line</b>	0.5 to 1.5m/sec
<b>Pressurization line</b>	2.0 to 8.0m/sec

### (2) Pressure

Fluid pressure in hydraulic circuits varies, e.g. negative pressure, static fluid, or impact pressure. The maximum working pressure (regular pressure) of the hose represents the maximum pressure for continuous use, and is generally set according to the relief set pressure.

However, since the impact pressure due to the opening and closing of circuits has serious influence on hose life, it is important to select suitable hoses so that the maximum impact pressure will not exceed the standard.

Although plastic is usually more rigid than rubber against negative pressure and can withstand small negative pressure, contact us if large negative pressure is expected.

The maximum impact pressure is about 1.5 times the maximum working pressure of case [A]. Refer to the catalog for case [B].

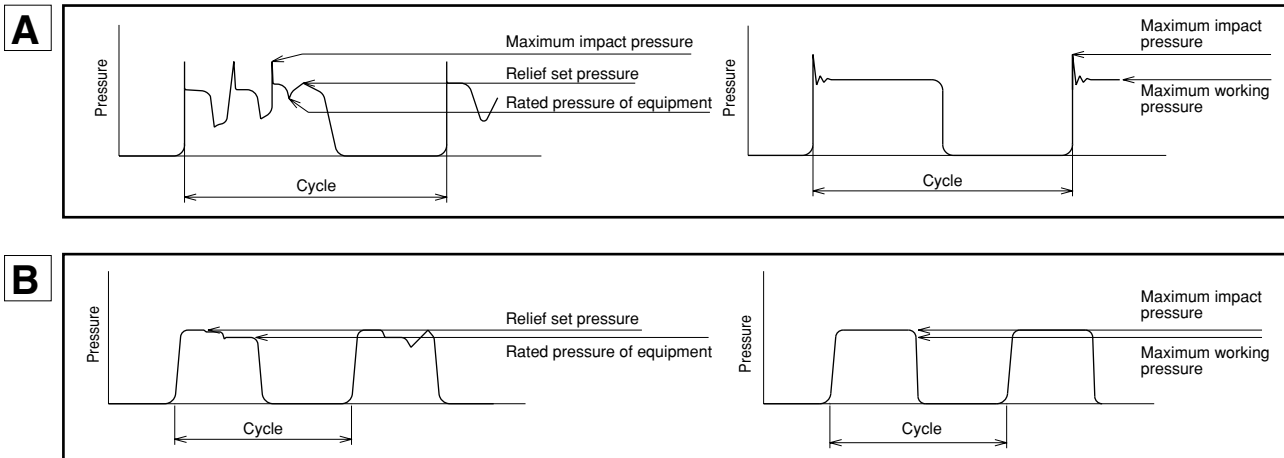

\* The test examples are the pressure waveforms used for the hydraulic impact test machine. In particular [B] is provided for JIS, pursuant to SAE and ISO.

Hydraulic Hose  
Airless-painting Hose  
Clean Hose  
Natural-Gas Hose  
Adaptor  
Hose Guard Part, Specially-Treated Part  
Assembling Machine, Jig, Tool  
Hose Assembling Method  
Technical Document  
Reference Document

### (3) Bending radius

The hose can be bent, but there is always a limit. If the hose is bent at a radius smaller than the minimum bending radius, deformation or kink of the hose may occur and cause problems. Please bend the hose at a radius larger than the minimum bending radius.

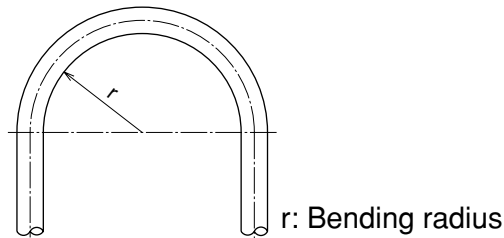

### (4) Coupling

The coupling consists of a connection to equipment, a hexagonal part, and a connection to the hose. There are various types of couplings, including adaptors. Sometimes connections to the imported equipment do not work well because their thread and sheet shape differs from the JIS standard. Therefore, check the thread type, sealing method and sheet surface shape and angle of equipment to be connected before selecting couplings.

### (5) Electrical insulation (nonconductive hose)

Plastic hoses in general have high electrical insulation. When electrical insulation is particularly necessary, e.g. for the hydraulic hose of electrical work equipment, leakage current is sometimes determined. Contact us in this case. When electrical insulation is required, a nonconductive hose without pin pricking (no pin hole for gas venting) is also available to prevent the reduction of electrical insulation due to external water invasion.

### (6) Fluid type

Since the hose core tube is made of high oil resistant plastic, it will not be damaged by mineral or aqueous hydraulic oil. However, some types of synthetic hydraulic oil and nonflammable special oil could affect the hose.

Typical couplings and adaptors are made of zinc galvanized steel. Contact us if using a special fluid that may damage the material or the surface processing.

☞ Stainless couplings or black colored couplings (made-to-order) are also available if using water or glycol hydraulic oil.

### (7) Working temperature (fluid temperature, atmospheric temperature)

Using a hose at a temperature higher than the specification may cause thermal degradation and could shorten the hose life. Also using at a temperature lower than the specification could make the hose harder and frangible. When effects of atmospheric temperature, e.g. radiational heat, are expected, use a heat insulator to protect the hose.

## Fixed piping

Since the length of the hose may change by  $\pm 3\%$  when pressurized, give some extra length to the hose to prevent shrinkage stress. Also since the minimum bending radius is determined for the specification of each hose, follow the standard and keep the hose straight (for about the same length as the outer diameter of the hose) near the coupling edge to prevent sharp bending.

### Formula when using the hose in a straight line

$$L = Y \times 1.03$$

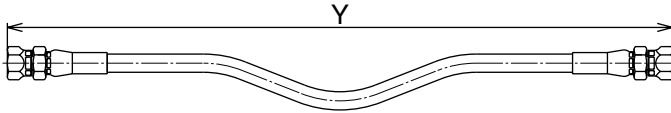

L: Length of hose assembly  
Y: Working straight length

### Formula when using the hose in a U-line

$$\ell = \pi (r + D/2) + 2D$$

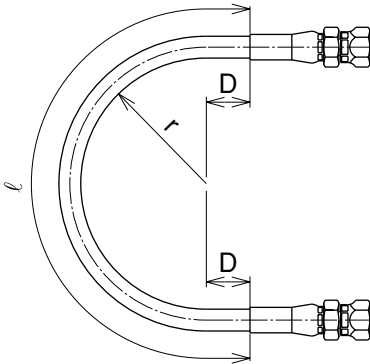

$\ell$ : Free length of hose  
 $\pi$ : Ludolphian number  
 $r$ : Minimum bending radius of hose  
 $D$ : Maximum outer diameter of hose

## Movable piping

For movable hose, determine the hose length with attention paid to the hose movement to prevent sharp bending or kink near the coupling edge.

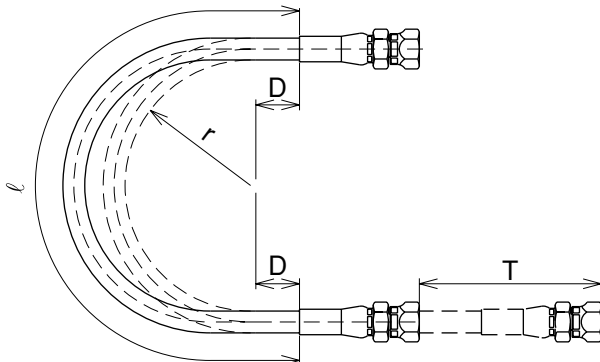

$$\ell = \pi (r + D/2) + 2D + T$$

$\ell$ : Free length of hose  
 $\pi$ : Ludolphian number  
 $r$ : Minimum bending radius of hose  
 $D$ : Maximum outer diameter of hose  
 $T$ : Stroke

## Explanation of nomograph

The figure below is to help in the selection of the most suitable choice of hose for equipment. Keep the flow velocity in the column. If the flow velocity exceeds the recommended value, problems such as increased pressure loss and overheating could occur. Generally, when fluid flows in a hose, the “flow volume”, “flow velocity”, and “hose cross section” are linked as shown in the formula below.

$$\text{Hose cross section (cm}^3\text{)} = \frac{\text{Flow volume (}\ell\text{/min)}}{\text{Flow velocity (m/sec)} \times 60} \times 10$$

Therefore, if any two of the three are given, the rest is determined by this formula.

## How to use the graph

- (1) Select the discharge flow volume of the pressure line in the leftmost line graph.
- (2) Select the flow velocity in the recommended range of the rightmost line graph.
- (3) Draw a line connecting both points obtained above and find the correct hose inner diameter at the point where the line crosses the central graph.

### [Nomograph]

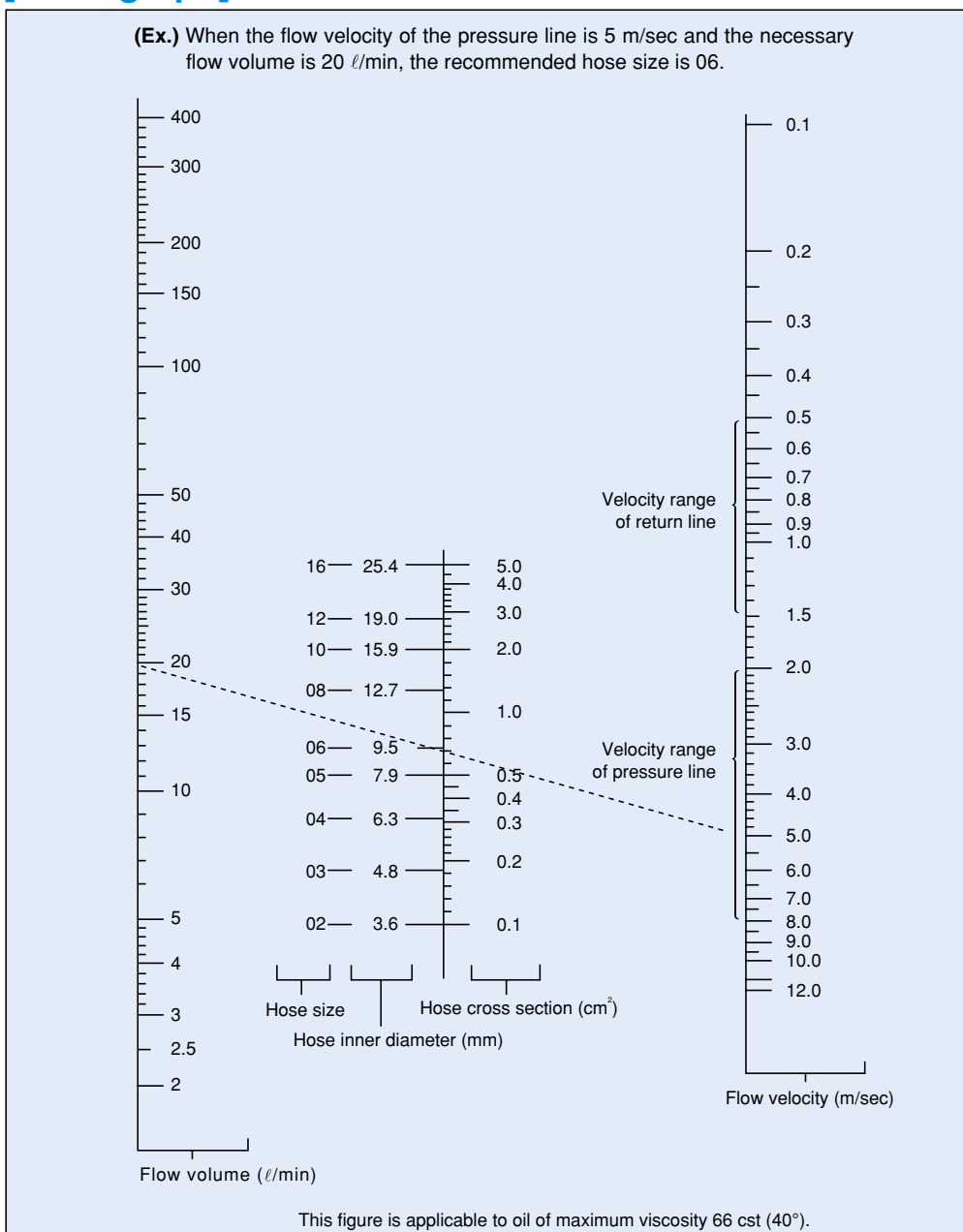

# Graphs for cubical expansion of hoses

## How to use the graph

- represents the maximum working pressure
- The hose size indicates inner diameter

☎ Please contact us for the details of 35NG series.

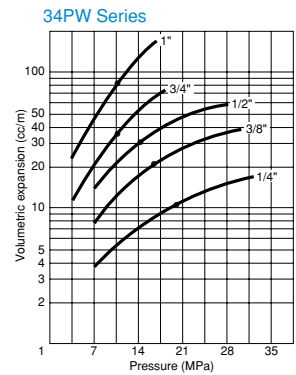
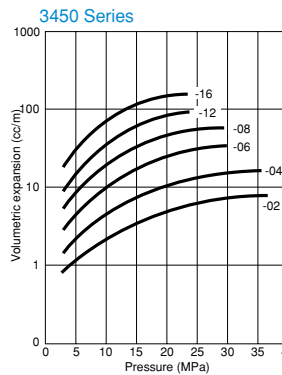
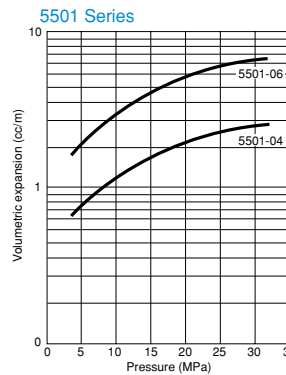
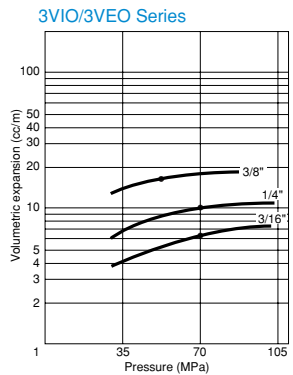
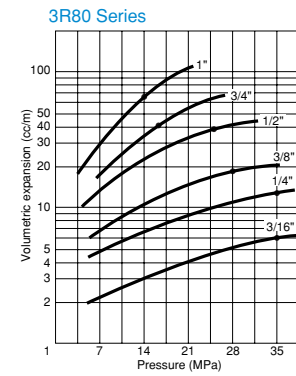
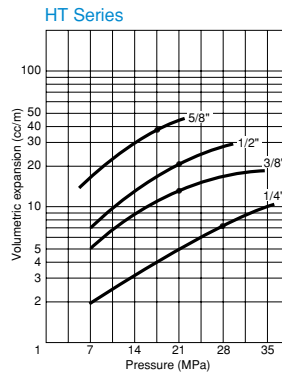
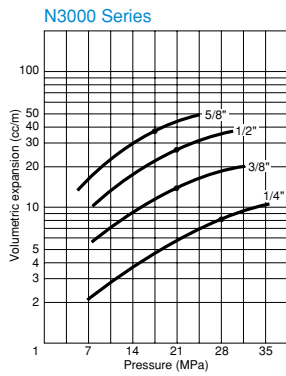
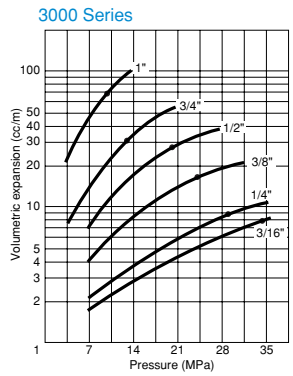
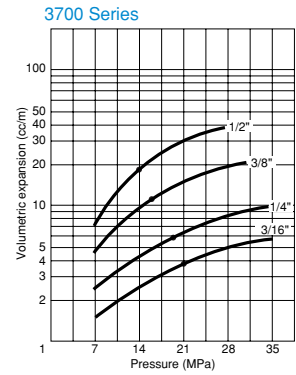
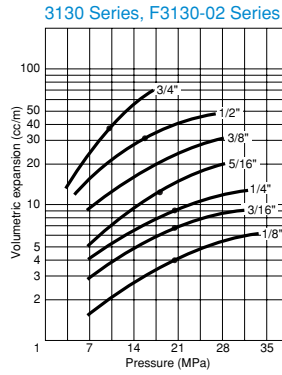
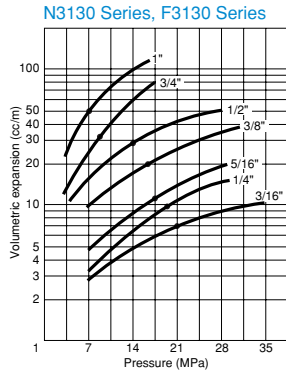
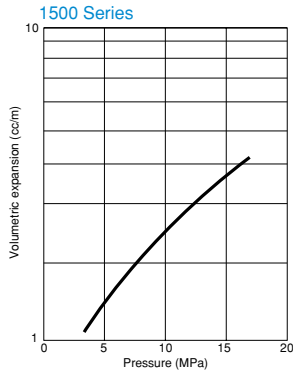
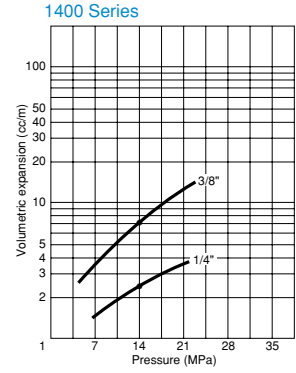
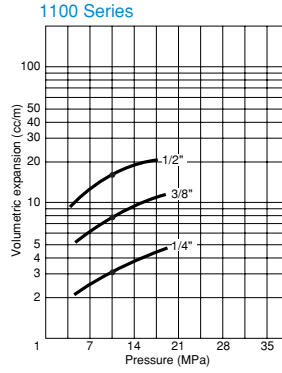
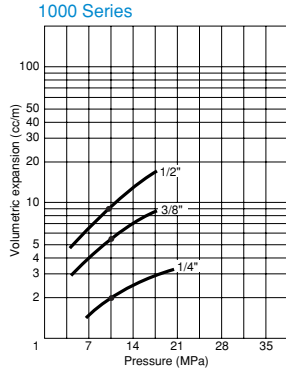
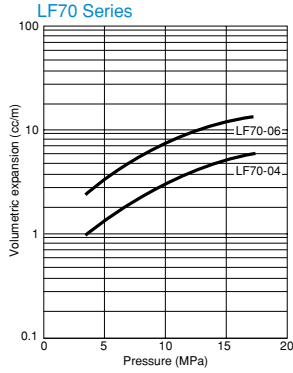

Hydraulic Hose

Anti-leak Hose

Clean Hose

Natural-Gas Hose

Adaptor

Hose Guard Part, Specially-Treated Part

Assembling Machine, Jig, Tool

Hose Assembling Method

Technical Document

Reference Document



## Parallel pipe thread

Thread size	1/8	1/4	3/8	1/2	3/4	1
G (PF) Thread	15N•m	25N•m	34N•m	59N•m	118N•m	137N•m

## Taper pipe thread

Thread size	1/8	1/4	3/8	1/2	3/4	1
R (PT) Thread	10 to 15N•m	25 to 30N•m	45 to 50N•m	60 to 70N•m	120 to 140N•m	140 to 160N•m

## Unified fine thread

Thread size	7/16-20	1/2-20	9/16-18	3/4-16	7/8-14
UNF Thread	25N•m	30N•m	40N•m	50N•m	60N•m

## American Standard straight pipe threads for free - fitting mechanical joints for fixtures

Thread size	1/4	3/8
NPSM Thread	25N•m	34N•m

## Steps to attach washer-faced elbow

**⚠ Caution:** Heavy-handed tightening with spanner, etc. may damage the body and washer.

### 1. Connecting

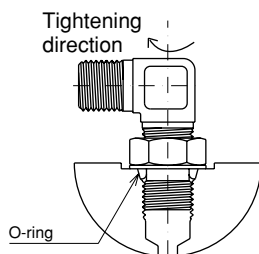

Screw in with your hand until the O-ring contacts the port.

**⚠ Caution:** Clean the O-ring and apply grease or operating oil to the ring.

### 2. Positioning

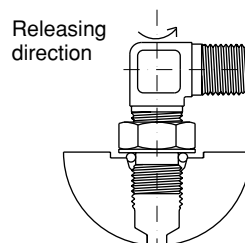

Release the screw until the elbow reaches the position of hose connection.

**⚠ Caution:** Do not rotate more than 360° from step 1.

### 3. Fixing

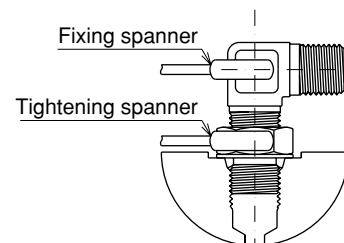

After connection to the hose, tighten the locknut with a spanner, etc.

**⚠ Caution:** See the list of locknut tightening torque. Try to maintain the right setting position.

## Shape and size of JIS-standard O-ring port (JISB2351)

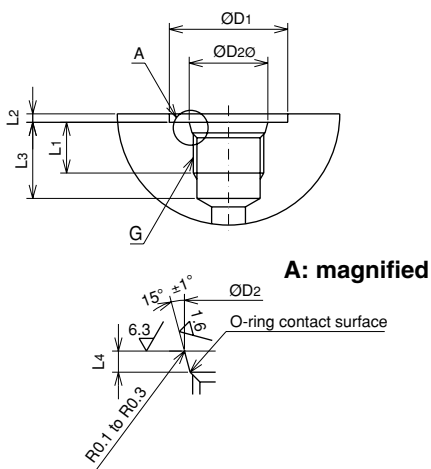

Thread name	$D_1 \pm 0.3$	$D_2^{+0.1}_0$	$L_1$ (Min)	$L_2$ (Max)	$L_3$ (Min)	$L_4^{+0.40}_0$	Suitable O-ring number
G							
1/8	18	11.6	10	1.0	15	2.0	P8
1/4	24	15.6	12	1.5	18	2.5	P11
3/8	28	18.6	12	2.0	18	2.5	P14
1/2	34	22.6	16	2.5	24	2.5	P18
3/4	45	29.8	17	2.5	25	3.5	P24
1	51	35.8	21	2.5	30	3.5	P29

- There must be no axial scratch or spiral tool mark on the O-shaped O-ring contact surface.
- D1 scraped surface must be square or flat to the thread axis.

# Connection method of hose coupling (with sheet) and adaptor

## 1. Coupling

Tighten with your hand until the two sheets perfectly contact each other.

⚠ **Caution:** Adjust the axes of the coupling and adaptor to prevent non-uniform contact of sheets. After tightening with your hand, please check for any unwanted space between the coupling and adaptor.

## 2. Fixing

Fix the adaptor and nipple with a spanner so that the sheets cannot rotate together, and tighten the nut with a torque wrench (see the figure). When the rotation speed of the torque wrench is high, the surface pressure at the sheet surface is low, which might cause leakage. In this case, slowly tighten again until you feel a click.

⚠ **Caution:** The tightening torque should follow the figures in the "parallel pipe thread" table on the previous page. If the sheets are rotated while contacting each other, it will damage the sheet surface and cause leakage.

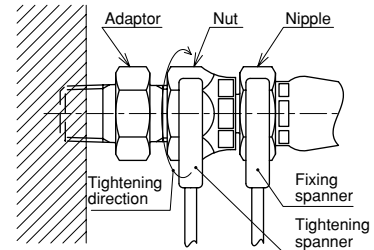

# Reference Document

<b><u>Technical standard for threads</u></b>	<b>92</b>
<b><u>Technical standard for plastic hoses</u></b>	<b>95</b>
<b><u>Table of unit conversion</u></b>	<b>96</b>
<b><u>Examples of problems when hose assembly is not used appropriately</u></b>	<b>97</b>
<b><u>Table of chemical resistance</u></b>	<b>98</b>

## Types

Thread symbol	Thread type	Related standard
G (PF)	Parallel pipe thread	JIS B0202
R (PT)	Taper pipe thread	JIS B0203
UNC	Unified coarse thread	JIS B0206
UNF	Unified fine thread	JIS B0208
M	Metric coarse thread	JIS B0205
M	Metric fine thread	JIS B0207
NPT	American Standard taper pipe threads for general use	ANSI B1/20/1
NPS	American Standard straight threads	ANSI B1/20/1
NPTF	Dryseal American Standard taper pipe threads	ANSI B1/20/3
NPSM	American Standard straight pipe threads for free-fitting mechanical joints for fixtures	ANSI B1/20/1

## Class

Thread type	Parallel male pipe thread		Unified thread						Metric thread	
	Class A	Class B	Class 3A	Class 3B	Class 2A	Class 2B	Class 1A	Class 1B	Female thread	Male thread
Class	Class A	Class B	Class 3A	Class 3B	Class 2A	Class 2B	Class 1A	Class 1B	4 H to 6 H	6 to 8g
Notation	A	B	3A	3B	2A	2B	1A	1B	4 H to 6 H	6 to 8g

## Expressional example

$\underset{\text{Thread symbol}}{G} \quad \underset{\text{Size}}{3/4} \quad \text{---} \quad \underset{\text{Class}}{B}$

$\underset{\text{Thread size}}{9/16} \quad \text{---} \quad \underset{\text{Number of screw threads}}{18} \quad \underset{\text{Thread symbol}}{\text{UNF}} \quad \text{---} \quad \underset{\text{Class}}{2B}$

$\underset{\text{Thread symbol}}{M} \quad \underset{\text{Thread size}}{18} \quad \text{x} \quad \underset{\text{Pitch}}{1.5} \quad \text{---} \quad \underset{\text{Class}}{2}$

## Parallel pipe thread [JIS BO202]

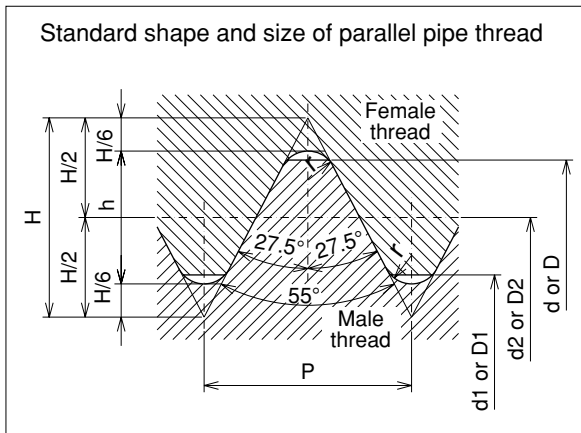

Thread name (PF)	Number of screw threads (per 25.4 mm) n	Pitch P (reference)	Height of thread h	Curvature of top r	Male thread		
					Outer diameter d	Pitch diameter d <sub>2</sub>	Root diameter d <sub>1</sub>
					Female thread		
					Root diameter D	Pitch diameter D <sub>2</sub>	Inner diameter D <sub>1</sub>
G1/8	28	0.9071	0.581	0.12	9.728	9.147	8.566
G1/4	19	1.3368	0.856	0.18	13.157	12.301	11.445
G3/8	19	1.3368	0.856	0.18	16.662	15.806	14.950
G1/2	14	1.8143	1.162	0.25	20.955	19.793	18.631
G3/4	14	1.8143	1.162	0.25	26.441	25.279	24.117
G1	11	2.3091	1.479	0.32	33.249	31.770	30.291

## Taper pipe threads [JIS BO203]

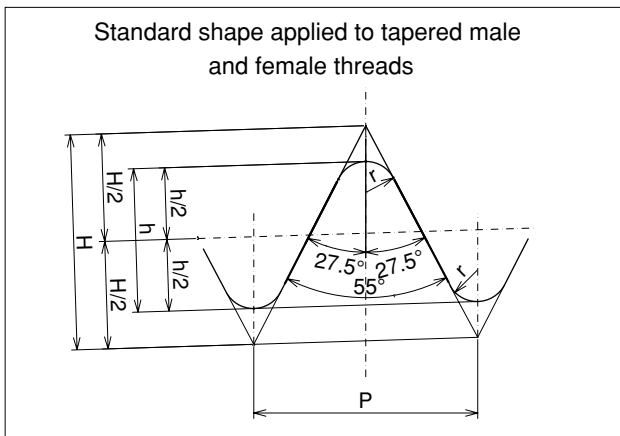

Thread name (PT)	Thread				Standard diameter			Position of standard diameter			Tolerance of D <sub>1</sub> , D <sub>2</sub> and D <sub>1</sub> of parallel female thread	Length of useful thread				Size of carbon-steel pipe (reference)	
	Number of screw threads (per 25.4 mm) n	Pitch P (reference)	Height of thread h	Curvature radius r or r <sub>2</sub>	Male thread			Male thread		Female thread		Male thread	Female thread		Without incomplete thread part		
					Outer diameter d	Pitch diameter d <sub>2</sub>	Root diameter d <sub>1</sub>	From pipe edge		At pipe edge		From position of standard diameter to larger diameter part	With incomplete thread part				
					Female thread			Standard length	Tolerance along axis	Tolerance along axis		From position of standard diameter to smaller diameter part	Taper female thread	Parallel male thread		Taper female thread, parallel female thread	
					Root diameter D	Pitch diameter D <sub>2</sub>	Inner diameter D <sub>1</sub>						From pipe or pipe coupling edge (reference)	From standard diameter, pipe, pipe coupling edge		From standard diameter, pipe, pipe coupling edge	Outer diameter
R1/8	28	0.9071	0.581	0.12	9.728	9.147	8.566	3.97	0.91	1.13	0.071	2.5	6.2	7.4	4.4	10.5	2.0
R1/4	19	1.3368	0.856	0.18	13.157	12.301	11.445	6.01	1.34	1.67	0.104	3.7	9.4	11.0	6.7	13.8	2.3
R3/8	19	1.3368	0.856	0.18	16.662	15.806	14.950	6.35	1.34	1.67	0.104	3.7	9.7	11.4	7.0	17.3	2.3
R1/2	14	1.8143	1.162	0.25	20.955	19.793	18.631	8.16	1.81	2.27	0.142	5.0	12.7	15.0	9.1	21.7	2.8
R3/4	14	1.8143	1.162	0.25	26.441	25.279	24.117	9.53	1.81	2.27	0.142	5.0	14.1	16.3	10.2	27.2	2.8
R1	11	2.3091	1.479	0.32	33.249	31.770	30.291	10.39	2.31	2.89	0.181	6.4	16.2	19.1	11.6	34.0	3.2

## Unified fine thread [JIS BO208]

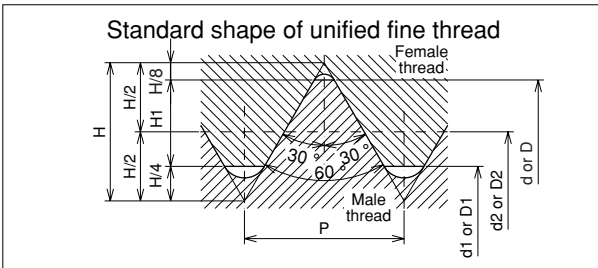

Thread name	Number of screw threads (per 25.4 mm) $n$	Pitch $P$ (reference)	Height of engagement $H_1$	Female thread		
				Root diameter $D$	Pitch diameter $D_2$	Inner diameter $D_1$
				Male thread		
				Outer diameter $d$	Pitch diameter $d_2$	Root diameter $d_1$
1/4 - 28 UNF	28	0.9071	0.491	6.350	5.761	5.367
5/16-24 UNF	24	1.0583	0.573	7.938	7.249	6.792
3/8 - 24 UNF	24	1.0583	0.573	9.525	8.837	8.379
7/16-20 UNF	20	1.2700	0.687	11.112	10.287	9.738
1/2 - 20 UNF	20	1.2700	0.687	12.700	11.874	11.326
9/16-18 UNF	18	1.4111	0.764	14.288	13.371	12.761
5/8 - 18 UNF	18	1.4111	0.764	15.875	14.958	14.348
3/4 - 16 UNF	16	1.5875	0.859	19.050	18.019	17.330
7/8 - 14 UNF	14	1.8143	0.982	22.225	21.046	20.262

## Metric fine thread [JIS BO207]

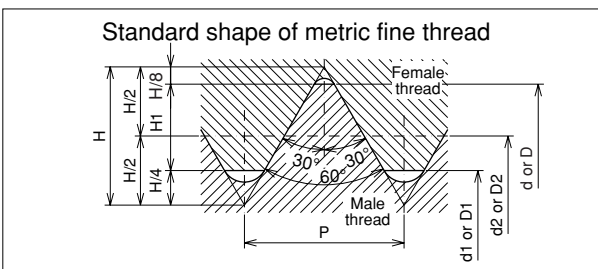

Thread name	Pitch $P$ (reference)	Height of engagement $H_1$	Female thread		
			Root diameter $D$	Pitch diameter $D_2$	Inner diameter $D_1$
			Male thread		
			Outer diameter $d$	Pitch diameter $d_2$	Root diameter $d_1$
M12 x 1.5	1.5	0.812	12.000	11.026	10.376
M14 x 1.5	1.5	0.812	14.000	13.026	12.376
M16 x 1.5	1.5	0.812	16.000	15.026	14.376
M18 x 1.5	1.5	0.812	18.000	17.026	16.376
M20 x 1.5	1.5	0.812	20.000	19.026	18.376
M22 x 1.5	1.5	0.812	22.000	21.026	20.376
M24 x 1.5	1.5	0.812	24.000	23.026	22.376
M30 x 1.5	1.5	0.812	30.000	29.026	28.376

# Technical standard for plastic hoses

Standard		Japan		ISO		USA		
		JIS K 6375 (Hose) JIS B 8362 (Hose assembly)		ISO 3949		SAE J 517		
Item	Type	Type 1	Type 2	Type 1	Type 2	100R7	100R8	
Main performance	Maximum working pressure	Minimum burst pressure x 1/4	←	←	←	←	←	
	Test pressure	Maximum working pressure x 2	←	←	←	←	←	
	Minimum burst pressure	Maximum working pressure x 4	←	←	←	←	←	
	Working temperature range	-40°C to +100°C	←	←	←	-40°C to +93°C	←	
	Fatigue resistance	Pressure	Maximum working pressure x 125%	Maximum working pressure x 133%	Maximum working pressure x 125%	Maximum working pressure x 133%	Maximum working pressure x 125%	Maximum working pressure x 133%
		Waveform	Square	←	←	←	←	←
		Frequency	150,000	200,000	150,000	200,000	150,000	200,000
		Oil temperature	93°C	←	←	←	←	←
		Cycle	30 to 75 cycle/min	←	←	←	←	←
		Oil type	Two types of JIS K2213 (turbine oil), ISOVG46 or equivalent	←	←	ISOVG46 of ISO3448	←	No specification
Change rate of length (at max. working pressure)	+3 to -3%	←	←	←	←	←	←	
Other performance	Low-temperature resistance	Bend hose at minimum bending radius, 8 to 12 sec after leaving it for 24 hr at -40°C. Then perform the pressure durability test.	←	←	←	←	←	
	Ozone resistance of outer surface	Perform visual check at two-fold magnification after leaving it for 72 hr at 40°C under the ozone concentration 0.5 ppm.	←	←	←	Perform visual check at seven-fold magnification after leaving it for 70 hr at 40°C under the ozone concentration 0.5 ppm.	←	
	Hydraulic resistance of inner and outer surface	+35 to -15% of volume change rate after dipping for 72 hr at 100°C in No. 3 oil.	←	←	←	+35 to -15% of volume change rate after dipping for 70 hr at 100°C in ASTM No. 3.	←	

## Length

m	in	foot	yard	mile
1	3.937 x 10	3.2808	1.0936	6.2 x 10 <sup>-4</sup>
2.54 x 10 <sup>-2</sup>	1	8.3333 x 10 <sup>-2</sup>	2.778 x 10 <sup>-2</sup>	1.6 x 10 <sup>-5</sup>
3.048 x 10 <sup>-1</sup>	1.2 x 10	1	3.3333 x 10 <sup>-1</sup>	1.9 x 10 <sup>-4</sup>
9.114 x 10 <sup>-1</sup>	3.6 x 10	3	1	5.7 x 10 <sup>-4</sup>
1.6093 x 10 <sup>3</sup>	6.3360 x 10 <sup>4</sup>	5.280 x 10 <sup>3</sup>	1.760 x 10 <sup>3</sup>	1

## Weight

kg	ton (UK)	ton (USA)	lb	Ounce
1	9.842 x 10 <sup>-4</sup>	1.1023 x 10 <sup>-3</sup>	2.2046	3.5274 x 10
1.016 x 10 <sup>3</sup>	1	1.12	2.240 x 10 <sup>3</sup>	3.5838 x 10 <sup>4</sup>
9.072 x 10 <sup>2</sup>	8.9286 x 10 <sup>-1</sup>	1	2 x 10 <sup>3</sup>	3.2 x 10 <sup>4</sup>
4.536 x 10 <sup>-1</sup>	4.464 x 10 <sup>-4</sup>	5 x 10 <sup>-4</sup>	1	1.6 x 10
2.835 x 10 <sup>-2</sup>	2.79 x 10 <sup>-5</sup>	3.13 x 10 <sup>-5</sup>	6.25 x 10 <sup>-2</sup>	1

## Pressure

Pa	MPa	bar	kgf/cm <sup>2</sup>	psi	mmHg
1	1 x 10 <sup>-6</sup>	1 x 10 <sup>-5</sup>	1.0197 x 10 <sup>-5</sup>	1.4504 x 10 <sup>-4</sup>	7.5006 x 10 <sup>-3</sup>
1 x 10 <sup>5</sup>	1 x 10 <sup>-1</sup>	1	1.0197	1.4504 x 10	7.5006 x 10 <sup>2</sup>
9.8067 x 10 <sup>4</sup>	9.8067 x 10 <sup>-2</sup>	9.8067 x 10 <sup>-1</sup>	1	1.4223 x 10	7.3556 x 10 <sup>2</sup>
6.8948 x 10 <sup>3</sup>	6.8948 x 10 <sup>-3</sup>	6.4898 x 10 <sup>-2</sup>	7.0307 x 10 <sup>-2</sup>	1	5.1715 x 10
1.3332 x 10 <sup>2</sup>	1.3332 x 10 <sup>-4</sup>	1.332 x 10 <sup>-3</sup>	1.3595 x 10 <sup>-3</sup>	1.934 <sup>1</sup> x 10 <sup>-2</sup>	1

## Force

N	dyn	kgf
1	1 x 10 <sup>5</sup>	1.0197 x 10 <sup>-1</sup>
1 x 10 <sup>-5</sup>	1	1.0197 x 10 <sup>-6</sup>
9.8066	9.8066 x 10 <sup>5</sup>	1

\*  is the SI unit.



# Examples of problems when hose assembly is not used appropriately

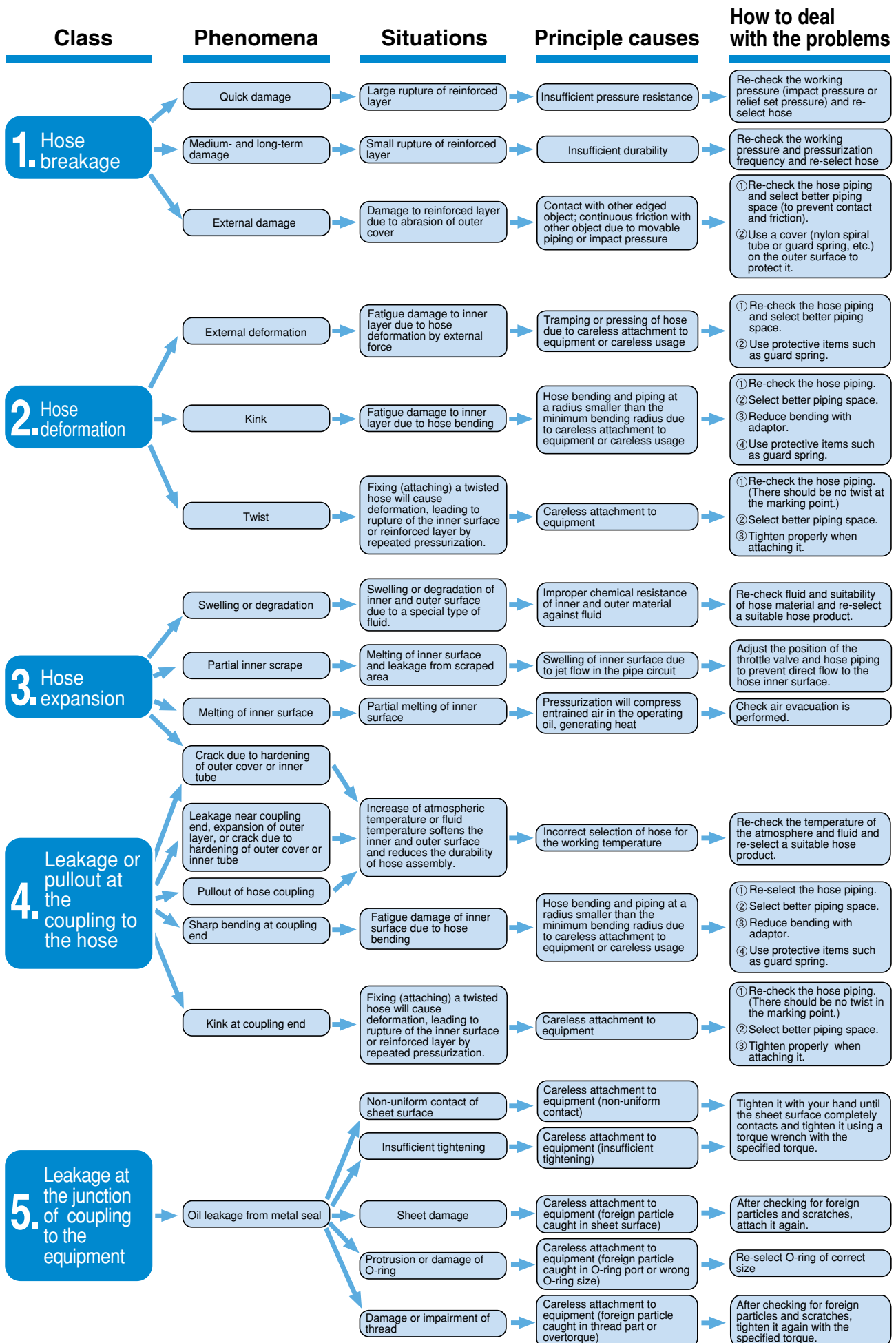

Please refer to the attached chemical resistance list for the safe use of the products. Special attention should also be paid to the explanation written below.

**[Criteria of availability for each chemical]**

- : No influence
- △ : Further confirmation required
- × : Not applicable
- : No data available

When consulting with us in case of △, following data are necessary for us to judge.  
 ①Pressure in operation, ②Max. temperature in operation, ③Concentration of chemicals,  
 ④Installation condition, ⑤Applicatio.

1. The data shown here are based upon laboratory. Variations in temperature, pressure, fluids duration of exposure or other special conditions influence the results in the list and therefore no guarantee is expressed or implied.
2. Please be sure to evaluate the products in the condition at a real workplace before use.
3. In case of aqueous solution in the list, the chemicals are all in a saturated condition at a room temperature, unless otherwise stated.
4. The list only shows chemical resistance at the liquid condition of chemicals but not referring at all to the gas permeation quality. Do not use the products for the chemicals which is dangerous if the gas permeates through/from the products.
5. Please consult with us about the chemical resistance for the galvanized materials.

- ☞ Campucka couplings are for the general operating oil and can not be used for any other kinds of liquids.
- ☞ When using the aqueous glycol operating oil, the materials for the couplings should be stainless or black oxidizing ones specially arranged upon request.

**Chemical resistance list (Guideline)**

Chemicals (Weight concentration %, Temperature °C)	Hose materials					Hose couplings/ Adaptors		
	Nylon	Polyolefi	Urethane	PVC	Polyester	Steel	SUS304	SUS316
2-Aminophenyl Disulfide								
A Acetaldehyde		×	×	×				
Acetic Acid (10%, 20°C)			×			×		
Acetic Acid (100%, 20°C)	×	×	×			×		
Acetic Acid (50%, 20°C)	×		×			×		
Acetic Acid (50%, 70°C)	×	×	×			×		
Acetic Anhydride	×		×	×	×	×		
Acetoamide		×						
Acetone			×	×				
Acetyl Bromide	×	×	×					
Acetyl Chloride	×	×	×	×	×			
Acetylene								
Acrylonitrile								
Alum	×							
Aluminium Acetate								
Aluminium Bromide								
Aluminium Chloride						×	×	×
Aluminium Fluoride							×	×
Aluminium Nitrate								
Aluminium Sulfate	×	×	×			×	×	×
Ammonia Anhydrous								
Ammonia Gas Cold	×	×	×					
Ammonia Gas Hot	×	×	×					
Ammonia Liquid								
Ammonia Water								
Ammonium Carbonate								
Ammonium Chloride						×		
Ammonium Hydroxide				×	×			
Ammonium Nitrate								
Ammonium Persulphate								
Ammonium Phosphate						×		
Ammonium Sulfate						×		
Amyl Acetate		×	×	×		×		
Amyl Alcohol								

The table shows relative merits under condition that cardinal number of aqueous liquor is based on saturated status with ordinary temperature unless otherwise specified.

	Chemicals (Weight concentration %, Temperature °C)	Hose materials					Hose couplings/ Adoptors		
		Nylon	Polyolefi	Urethane	PVC	Polyester	Steel	SUS304	SUS316
A	Amyl Borate								
	Amyl Naphthalene								
	Anethole								
	Aniline	x	x	x		x	x		
	Aniline Dyes	x							
	Animal oil (Lard oil)						x		
	Aqua Regia	x	x	x					
	Arsenic Acid								
	Asphalt								
	ASTM lubricant No.1		x						
	ASTM lubricant No2		x	x					
	ASTM lubricantNo.3		x	x					
	ASTM Standard fuel oil A		x						
	ASTM Standard fuel oil B		x						
	ASTM Standard fuel oil C		x						
B	Balium Hydroide						x		
	Barium Chloride						x		
	Barium Sulfate								
	Barium Sulfide								
	Beet sugar oil								
	Benzene		x	x	x				
	Benzin		x						
	Benzoaldehyde		x		x		x		
	Benzoic Acid			x		x	x		
	Benzyl Alcohol								
	Benzyl Benzoate								
	Benzyl Chloride	x							x
	Borax								
	Boric acid						x		
	Bromine	x	x	x		x	x		x
	Bunker fuel								
	Buthane								
	Butyl Acetate		x	x	x				
	Butyl Acrylate		x						
	Butyl Alcohol								
	Butyl Cellosolve								
	Butyl Stearate								
C	Calcium Acetate								
	Calcium Arsenate								
	Calcium Bisulfite						x		
	Calcium Chloride								
	Calcium Hydroxide								
	Calcium Hypochlorite (20%, 20°C)	x		x			x		
	Calcium Nitrate								
	Calcium Sulfide								
	Cane sugar liquor								
	Carbitol								
	Carbon Dioxide								
	Carbon Oxide								
	Carbon Tetrachloride	x	x	x		x			
	Carbone Disulfide	x	x	x	x				
	Carbonic Acid						x		
	Castor Oil								
	Cellosolve								
	Cellosolve Acetate			x					
	Chloride gas (dry)	x	x	x		x		x	x
	Chloride gas (wet)	x	x	x				x	x
	Chloro acetone		x						
	Chlororform		x	x			x		
	Chlorosulfonic acid	x	x					x	x

The table shows relative merits under condition that cardinal number of aqueous liquor is based on saturated status with ordinary temperature unless otherwise specified.

	Chemicals (Weight concentration %, Temperature °C)	Hose materials					Hose couplings/ Adaptors		
		Nylon	Polyolefi	Urethane	PVC	Polyester	Steel	SUS304	SUS316
C	Chlorotoluene	x	x						
	Chromic Acid (10%, 70°C)	x	x	x		x	x	x	
	Chromic Acid (2%, 50°C)	x	x	x		x	x	x	
	Chromic acid (2%, 70°C)	x	x	x		x	x	x	
	Chromic acid (25%, 70°C)	x	x	x		x	x	x	
	Citric acid						x		
	Coal-Tar								
	Copper Chloride						x	x	x
	Copper Cyanide								
	Copper Sulfate						x		
	Corn oil								
	Cotton seed oil								
	Creosote	x		x		x			
	Cresol	x	x	x		x			
	Cyclohexane		x						
	Cyclohexanol								
	Cyclohexanone		x	x					
D	Decalin								
	Developer (Hypo)								
	Diacetone Alcohol				x				
	Dibenzine Ether		x	x					
	Dibutyl Ether		x						
	Dibutyl Phthalate								
	Dichlorobenzene		x	x					
	Diethanol Amine								
	Diethyl Ether (< Ethyl Ether)								
	Diethyl Ether								
	Diethyl Sebacate		x						
	Diisopropyl Ketone			x					
	Dimethyl Formamide	x		x					
	Dinitrogen oxide (Nitrous Oxide)		x	x			x		
	Diocetyl Phthalate (DOP)		x		x				
	Diocetyl Sebacate (DOS)		x						
	Dipentene (Limonene)		x	x					
	Diphenyl		x	x					
	Diphenyl Oxide								
	Dowtherm (100°C)								
Dowtherm (200°C)									
E	Epichlorohydrin	x							
	Ester Silicate								
	Ethanol Amine	x	x						
	Ethyl Acetate			x	x				
	Ethyl Acetoacetate								
	Ethyl Acrylate			x					
	Ethyl Alcohol			x					
	Ethyl Benzene		x						
	Ethyl Cellulose								
	Ethyl Chloride		x	x	x	x			
	Ethyl Oxalate		x	x					
	Ethyl Silicate								
	Ethylene Chlorohydrin	x	x	x	x	x			
	Ethylene Diamine	x	x						
	Ethylene Dioxide	x		x	x	x			
	Ethylene Glycol								
	Ethylene Oxide		x	x					
F	Fatty Acids		x				x		
	Ferric Chloride						x	x	x
	Ferric Chloride								
	Ferric Nitrate (II)								
	Fluorine		x	x		x	x		

Hydraulic  
Hose

Airless-  
painting  
Hose

Clean  
Hose

Natural-Gas  
Hose

Adaptor

Hose Guard  
Part, Specially-  
Treated Part

Assembling  
Machine,  
Jig, Tool

Hose  
Assembling  
Method

Technical  
Document

Reference  
Document

The table shows relative merits under condition that cardinal number of aqueous liquor is based on saturated status with ordinary temperature unless otherwise specified.

	Chemicals (Weight concentration %, Temperature °C)	Hose materials					Hose couplings/ Adoptors		
		Nylon	Polyolefi	Urethane	PVC	Polyester	Steel	SUS304	SUS316
F	Fluoroboric acid			x		x			
	Formaldehyde (40%, 20°C)	x		x					
	Formic acid (25%, 20°C)	x		x		x	x		
	Formic acid (50%, 20°C)	x		x			x		
	Formic acid (90%, 20°C)	x		x			x		
	Freon 114								
	Freon 12								
	Freon 21								
	Freon 22								
	Freon11								
	Freon113								
	Furan	x							
	Furfural	x	x	x					
	Furfuryl Alcohol								
G	Gasoline			x					
	Gelatine								
	Glucose								
	Glue								
	Glycerine								
	Grease								
H	Heavy water								
	Heptane		x						
	Hexane		x						
	Hexyl Alcohol								
	Hydrazine								
	Hydrobromic Acid (20%, 20°C)						x	x	
	Hydrobromic Acid (20%, 70°C)	x					x	x	
	hydrobromic Acid (37%, 20°C)						x	x	
	Hydrochloric Acid (10%, 20°C)			x		x	x	x	
	Hydrochloric Acid (20%, 20°C)	x		x		x	x	x	
	Hydrochloric Acid (20%, 80°C)	x	x	x		x	x	x	
	Hydrochloric Acid (38%, 20°C)	x		x		x	x	x	
	Hydrocyanic Acid	x					x		
	Hydrofluoric Acid (10%, 20°C)	x		x		x	x	x	
	Hydrofluoric Acid (20%, 20°C)	x		x		x	x	x	
	Hydrofluoric Acid (40%, 20°C)	x		x		x	x	x	
	Hydrofluoric Acid (Anhydrous)	x	x	x			x		x
	Hydrogen								
	Hydrogen Peroxide (30%, 20°C)	x		x		x	x		
	Hydrogen Peroxide (5%, 20°C)						x		
	Hydrogen Peroxide (5%, 50°C)			x			x		
	Hydrogen Sulfide								
	Hydroquinone								
	Hypochlorous acid			x					
I	Isobutyl Alcohol								
	Isocyanates								
	Isooctane		x	x					
	Isopropyl Acetate		x		x				
	Isopropyl Alcohol								
	Isopropyl Ether								
J	JP fuel oil		x						
K	Kerosene								
	Kerosene								
	Ketones				x				
L	Lacquer				x				
	Lactic Acid								
	Lard oil								
	Lead Acetate					x			
	Lead Arsenate								
	Lead Nitrate								

The table shows relative merits under condition that cardinal number of aqueous liquor is based on saturated status with ordinary temperature unless otherwise specified.

	Chemicals (Weight concentration %, Temperature °C)	Hose materials					Hose couplings/ Adoptors		
		Nylon	Polyolefi	Urethane	PVC	Polyester	Steel	SUS304	SUS316
L	Lead Sulfamate								
	Lead Sulfate						x		
	Linoleic acid Dipentene								
	Linseed oil		x						
	Liquid Chloride	x	x	x					
	Liquidified Petroleum Gas								
	Lubricant (Ether type)		x	x					
	Lubricant (mineral oil type)		x						
	Lye solutions								
M	Magnesium Chloride							x	x
	Magnesium Hydroxide ,								
	Magnesium Sulfate								
	Maleic acid								
	Malic Acid								
	Mercaptane		x						
	Mercuric Chloride						x	x	x
	Mercury								
	Methane				x				
	Methyl Acetate			x	x				
	Methyl Alcohol			x	x				
	Methyl Bromide		x	x	x	x			
	Methyl Chloride	x	x	x	x	x			
	Methyl Iso Butyl Ketone			x	x				
	MethylEthyl Ketone			x	x				
	Methylene Dichloride	x		x					
	Metyl Metacrylate		x						
	Metyl Sulfate		x	x					
	Mineral oil								
	Monochloro Acetic Acid	x	x	x	x	x			
	Monochloro Benzene	x	x	x					
	Monoethanol Amine								
N	Naphtha		x		x				
	Naphthalene				x				
	Naphthenic acid								
	Natural gas								
	n-Hexa Aldehyde		x						
	Nickel Acetate								
	Nickel Chloride	x			x	x	x		x
	Nickel Sulfate						x		
	Nitric acid (10%, 20°C)	x		x			x		
	Nitric Acid (10%, 70°C)	x		x			x		
	Nitric Acid (30%, 20°C)	x		x		x	x		
	Nitric Acid (30%, 70°C)	x	x	x		x	x		
	Nitric Acid (61%, 20°C)	x	x	x		x	x		
	Nitric Acid (fuming 20°C)	x	x	x		x	x		
	Nitrobenzene	x	x	x	x	x			
	Nitroethane		x						
	Nitrogen								
	Nitromethane		x						
	Nitropropane		x						
O	Octyl Alcohol	x							
	Oleic Acid								
	Olive Oil								
	Oxalic Acid						x	x	
	Oxygene								
	Ozone								
	Palm oil								
	Palmitin Acid								
	Pentane		x						
	Perchloroethylene	x	x	x		x			

Hydraulic  
Hose

Airless-  
painting  
Hose

Clean  
Hose

Natural-Gas  
Hose

Adaptor

Hose Guard  
Part, Specially-  
Treated Part

Assembling  
Machine,  
Jig, Tool

Hose  
Assembling  
Method

Technical  
Document

Reference  
Document

The table shows relative merits under condition that cardinal number of aqueous liquor is based on saturated status with ordinary temperature unless otherwise specified.

	Chemicals (Weight concentration %, Temperature °C)	Hose materials					Hose couplings/ Adoptors		
		Nylon	Polyolefi	Urethane	PVC	Polyester	Steel	SUS304	SUS316
P	Petroleum		x						
	Phenol	x		x		x	x		
	Phenyl Disulfide		x						
	Phenyl Hydrazine								
	Phorone								
	Phosphoric Acid (50%, 20°C)			x		x			
	Phosphoric Acid (50%, 70°C)	x		x		x	x		x
	Phosphoric Acid (75%, 20°C)	x		x			x		
	Phosphorobenzene								
	Pickling Acid (Nitric acid 20% / Fluoric acid 4%)	x							
	Pickling Acid (Nitric acid 40% / Fluoric acid 15%)	x							
	Picric Acid	x		x		x			
	Pine oil	x	x						
	Pinene		x						
	Piperidine								
	Potassium Bichromate					x			
	Potassium Chloride						x		
	Potassium Cyanide								
	Potassium Hydroxide					x			
	Potassium Nitrate								
	Potassium Perchlorate	x		x		x	x	x	x
	Potassium Permanganate (5%, 20°C)	x		x					
	Potassium Sulfate						x		
	Propane								
	Propyl Acetate		x	x					
	Propyl Alcohol			x					
	Propylene								
	Pyridine	x			x				
	Pyrrole								
S	Salicylic Acid								
	Salt Water (Brine)								
	Sea Water								
	Silicone Grease								
	Silicone oil								
	Silver Nitrate								
	Soap aqueous solution								
	Soda Ash								
	Soda (Carbonated) water								
	Sodium Bicarbonate								
	Sodium Bisulphate ,								
	Sodium Carbonate								
	Sodium Cyanide								
	Sodium Hydroxide						x		
	Sodium Hydroxide (30%, 20°C)			x					
	Sodium Hydroxide (30%, 70°C)	x	x	x					
	Sodium Hydroxide(10%, 20°C)			x					
	Sodium Hypochlorite (5%, 20°C)	x		x			x	x	
	Sodium Hypochlorite(5%, 70°C)	x		x			x	x	
	Sodium Metaphosphate								
	Sodium Nitrate								
	Sodium Perborate								
	Sodium Peroxide	x							
	Sodium Phosphate						x		
	Sodium Silicate								
	Sodium Sulfate								
	Sodium Sulfide								
	Sodium Sulfite	x	x						
	Sodium Thiosulfate						x		
	Soy Bean oil								
	Stannic Chloride							x	x

The table shows relative merits under condition that cardinal number of aqueous liquor is based on saturated status with ordinary temperature unless otherwise specified.

	Chemicals (Weight concentration %, Temperature °C)	Hose materials				Hose couplings/ Adoptors			
		Nylon	Polyolefi	Urethane	PVC	Polyester	Steel	SUS304	SUS316
S	Stannous chloride						x	x	x
	Stearic Acid						x		
	Styene								
	Sulfur								
	Sulfur Chloride		x						
	Sulfur Dioxide	x	x	x					
	Sulfur Trioxide			x		x			
	Sulfuric Acid (10%, 20°C)			x		x	x	x	x
	Sulfuric Acid (10%, 70°C)	x		x			x	x	x
	Sulfuric Acid (30%, 20°C)	x		x		x	x	x	x
	Sulfuric Acid (30%, 70°C)	x	x	x			x	x	x
	Sulfuric Acid (98%, 20°C)	x	x	x			x	x	x
Sulfuric Acid (fuming 20°C)	x	x	x						
Sulfurous Acid	x	x	x						
T	Table Salt (Common Salt)								
	Tannic Acid								
	Tartaric acid								
	Terpineol		x						
	Tetrachloro Ethane		x						
	Tetraethyl Lead								
	Tetrahydro Furan		x						
	Tetraline		x						
	Tetrametyl Lead								
	Thionyl Chloride	x	x						
	Toluene		x	x	x				
	Triacetine								
	Tributoxyethyl Phosphate								
	Tributyl Phosphate		x		x				
	Trichloroacetate	x		x		x			
	Trichloroethylene		x	x		x			
	Tricresyl Phosphate		x						
	Triethanolamine		x						
	Tung oil								
	Turpentine oil		x						
U	Uric acid			x		x			
V	Vegetable oil								
X	Xylene		x	x	x				
Z	Zeolite								
	Zinc Acetate								
	Zinc Chloride								
	Zinc Sulfide						x		

Hydraulic  
Hose

Airless-  
painting  
Hose

Clean  
Hose

Natural-Gas  
Hose

Adaptor

Hose Guard  
Part, Specially-  
Treated Part

Assembling  
Machine,  
Jig, Tool

Hose  
Assembling  
Method

Technical  
Document

Reference  
Document



# NITTA MOORE COMPANY

nm\_info@nitta.co.jp

Overseas Development 4-4-26, Sakuragawa, Naniwa-ku, Osaka, 556-0022, Japan  
Phone.81-6-6563-1270 Fax.81-6-6563-1273

---

## KOREA NITTA MOORE CORPORATION

145-6, Gong Dan Dong, Kumi-City, Kyung-Buk, 730-030, Korea Phone. 546-461-5575 Fax. 546-461-5350

## NITTA MOORE AMERICA, INC.

3075 Breckinridge Blvd., Suite 405, Duluth, Georgia 30096, U.S.A. Phone.770-295-3000 Fax.770-295-3007

## TAIWAN NITTA FILTER CO.,LTD.

Chia Hsin Building 10F Room, No.1005, 96 Chung Shan North Road Section 2 Taipei, Taiwan R.O.C. Phone. 02-2581-6296 Fax. 02-2563-4900

## NITTA CORPORATION OF SINGAPORE PTE LTD

101 Lorong 23, Geylang, #07-01 Prosper House, Singapore 388399 Phone. 748-0873 Fax. 748-0989

## NITTA INDUSTRIES EUROPE GMBH

Hansaallee 201 40549 Düsseldorf Germany Phone.0211-537535-0 Fax.0211-537535-35

AGENCY

00 05 07 05000

The specifications in this catalog may be changed  
for improved products without prior notice.



\*CATA-10010A

\*